

Industrial power brushes

Table of contents



Contents		Page
■ General information		3
■ The fast way to the best tool		4
■ Safety notes and dimensions		6
■ Cutting speeds and recommendations for use		7
■ Filament materials and their application		8
■ Information on processing stainless steel (INOX)		9
■ Well packed and presented		10
Drive	Contents	Page
	Wheel brushes	
		Crimped wheel brushes 11
		Knotted wheel brushes 15
	Stationary brushes	
		Wheel brushes 19
		Composite wheel brushes 21
	Wheel brushes	
		Wheel brushes for burnishing machines 23
		Shank mounted end brushes 24
	Shank mounted wheel brushes	
		Shank mounted wheel brushes 28
	Shank mounted bevel brushes	
	Shank mounted bevel brushes 30	
	Shank mounted cup brushes	
		Shank mounted cup brushes 31

Drive	Contents	Page	
	Brush sets		
		Brush sets 31	
	Threaded cup brushes		
		Threaded cup brushes 32	
	Threaded bevel brushes		
		Threaded bevel brushes 35	
	Brushes INOX-TOTAL		
		Brushes INOX-TOTAL 37	
	Tube brushes		
		Tube brushes 40	
	Scratch brushes		
		Scratch brushes 42	
	Accessories		
		Arbors and adapters 44	
	Brushes in POS packaging		
		Overview 47	
	Angle grinder		Burnishing machine/roller drive
	Flexible shaft drive		Straight grinder
	Stationary use		Drilling machine
	Robot applications		Manual application

PFERD brushes

PFERD industrial power brushes are quality tools for surface machining. PFERD offers a comprehensive range of high-quality brushes for professional machining of various materials and applications. Within the PFERD range, you can find the best brush for every application, for every machining problem and for every material.

PFERD quality is certified according to ISO 9001.

Advantages:

- Special quality wires (oil tempered wire) with high flexibility and bending fatigue strength ensure long tool life
- High concentricity due to even distribution and secure fixing of the filament material

- Optimum finishing result due to close matching of brush body and visible trim lengths
- Good price-performance ratio

More brushing in less time

PFERD produces knotted wheel and bevel brushes according to a specific manufacturing process. The special fixation of the brush knots contributes to a significant increase in performance.

Advantages:

- 25 % longer service life than other commercially available knotted brushes
- Savings in set-up times, reduction of tool costs and greater cost-effectiveness



The fast way to the best tool

To help you find the optimum brush tool, we have summarized the most important applications and the tools from our product range which are suitable for your tasks on pages 4–5.

1 Select filament material

First, the optimum filament material for the brush application is chosen to suit the material to be machined. The filament materials are colour-coded for easier recognition:

Steel wire	–	grey
Stainless steel wire	–	blue
Brass wire	–	yellow
Plastic filament	–	red

2 Select filament type

Depending on the desired brushing effect, you can choose between the crimped, knotted or encapsulated filament types.

3 Select tool

The best suitable tool can be found below your application.

Industrial power brushes are mainly used for:

- **Deburring**, especially removal of secondary burrs produced by milling, grinding, turning or drilling
- **Surface machining**
 - **Cleaning**
 - Removal of rust, removal of scale
 - Weld dressing
 - Cleaning, removal of paint
 - **Structuring surfaces**
 - Matt finishing, satinizing
 - Roughening, texturing

Industrial power brushes				The fast way to the best tool		PFERD	
Filament material selection		Filament type selection		Tool selection		Testing the tool	
Material to be machined	Material to be machined	Advantages / properties	Application	Flament type	Brush code	Brush code	Brush code
Construction material	Color code	Color code	Color code	Color code	Color code	Color code	Color code
Steel wire (B2C)	grey	Tough, high tensile strength	Light surface finishing	knotted	BBU 42	BBU 23	BBU 25
Stainless steel wire (B2C)	blue	Resistant to high temperatures	Removal of burrs on polished, oxidized and painted surfaces	knotted	BBU 42	BBU 23	BBU 25
Brass wire	yellow	Clear, not too hard	Removal of burrs on painted, oiled and insulating material from unvarnished surfaces	knotted	BBU 42	BBU 23	BBU 25
Plastic filament	red	High flexibility	Removal of rust, scale, etc.	knotted	BBU 42	BBU 23	BBU 25

Ordering instructions

When ordering, please state the EAN or the complete description.

Ordering example:

EAN 4007220153017
RBU 3006/6 ST 0.20

Ordering example explanation:

RBU = Wheel brush, crimped
30 = Brush diameter d_1 [mm]
06 = Face width b [mm]
/6 = Shank diameter d_3 [mm]
ST = Filament material, steel
0,20 = Filament diameter d_6 [mm]

PFERDERGONOMICS®

The PFERDERGONOMICS® programme aims at the long-term reduction of dust, noise and vibration levels produced by tools, and on perceptibly increasing tool haptics. The focus is on people.

Recognize straight away the areas where our tools offer you advantages. Tools with PFERDERGONOMICS® properties are marked with corresponding pictograms.

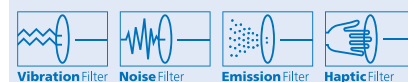

PFERD offers industrial power brushes in the COMBITWIST® design to significantly reduce vibrations during use and to noticeably improve machining comfort.

Technical customer support

Your PFERD sales representative will advise you free of charge and without obligation on site and is available to assist you in solving your application problems and to answer all queries regarding the safe use of PFERD brushes.

Products made to order

If you cannot find the solution for your particular application in our comprehensive product range, we can produce brushes in premium PFERD quality on request, tailor-made to meet the requirements of your job. Additional wire sizes and qualities, arbor holes or threaded holes and custom dimensions are available as made-to-order products.























PFERDVIDEO

You will receive more information here or at www.pferd.com

Industrial power brushes

The fast way to the best tool



① Filament material selection From the material to be machined to the filament material			② Filament type selection From the application to the filament type		③ Tool selection							
Material to be machined ▼	Filament material ▼	Advantages/properties ▼	Application ▼	Filament type ▼	Weld seam		Texturing the surface					
						Page		Page				
Construction steel, carbon steel, alloyed steels, non-alloyed steels, plastics	Steel wire (ST) Colour code: grey	<ul style="list-style-type: none"> Tough, high tensile strength Long service life Suitable for high rotational speeds General purpose tool Low cost 	<ul style="list-style-type: none"> Light surface finishing Removal of burrs on contours, cut-outs and pipes, removal of rust, paint, scale and insulating material 	crimped 		HBU	42		WBU	23		
			<ul style="list-style-type: none"> Weld dressing Removal of rust, slag, scale, etc. 	knotted 		RBG	29		RBG PIPE	17		
			<ul style="list-style-type: none"> Precise, localized rust removal, deburring and cleaning 	encapsulated 		RBV	30					
Stainless steel (INOX), aluminium, other non-ferrous metals	Stainless steel wire (INOX) Colour code: blue	<ul style="list-style-type: none"> Corrosion-resistant Resistant to high thermal loads Does not leave any corrosive residues behind on the workpiece Can be used at lower rotational speeds, compared to steel wire Brushes with stainless steel trims are usually degreased 	<ul style="list-style-type: none"> Light surface finishing Removal of burrs on contours, cut-outs and pipes, removal of rust, paint, scale and insulating material from rust-resistant surfaces 	crimped 		HBU	42		WBU	23		
			<ul style="list-style-type: none"> Weld dressing Removal of rust, slag, scale, etc. on stainless steel surfaces 	knotted 		RBG RBGIT	29 38		RBG PIPE	17		
Non-ferrous metals, stainless steel (INOX), aluminium, titanium, wood, plastics, steel, casting	Plastic filament (SiC, CO, nylon) Colour code: red	<ul style="list-style-type: none"> High level of elasticity and flexibility An even, abrasive effect Sensitive to heat, may therefore require the use of grinding oil for cooling 	<ul style="list-style-type: none"> High flexibility permits work in hard-to-reach areas Deburring, cleaning and grinding Matt finishing, texturing and satinizing of surfaces 	crimped 					RBU	11, 20		
									RBUP	21		
Brass, copper, other non-ferrous metals	Brass wire (MES) Colour code: yellow	<ul style="list-style-type: none"> Works without sparking Flexible Fine surface finish on aluminium 	<ul style="list-style-type: none"> Light surface finishing Removal of corrosion, paint, scale and insulating material Cleaning of CU solder joints 	crimped 		HBU	42					

③ Tool selection														
Edge			Deburring Surface			Interior			Cleaning Surface			Cleaning Interior		
														
Page			Page			Page			Page			Page		
 KBU	30, 35		 RBU	28		 PBU	24		 RBU	11-14, 28		 PBU	24	
 RBU	11-13, 20		 RBU	11-14, 20		 PBUR	26		 TBU	31-32		 PBUR	26	
			 TBU	31-32		 IBU	40-41		 HBU	42		 IBU	40-41	
 KBG	35		 RBG	15, 19		 PBGS	26		 RBG	29		 PBGS	26	
 KBG CT	36		 RBG CT	15, 19, 16					 RBG CT	15, 19, 16		 PBGS	27	
 RBG	19		 TBG	33		 PBG	27		 KBG	35		 PBG	27	
			 TBG CT	34					 KBG CT	36				
									 TBG	33				
									 TBG CT	34				
 RBV	30					 PBV	25					 PBV	25	
 KBU	30, 35		 RBU RBUIT	28, 38		 PBU RBUIT	24, 37		 RBU RBUIT	11-14, 28, 38		 PBU RBUIT	24, 37	
 KBUIT	38		 RBU	11-14, 20		 IBU	40-41		 TBU	32-33		 IBU	40-41	
 RBU	11-13, 20		 TBU	31-32		 PBUR	26		 KBU KBUIT	30, 35, 38		 PBUR	26	
									 HBU	42				
									 HBUP	42				
 KBG	35		 RBG	15		 PBGS	26		 RBG	29		 PBGS	26	
			 RBG CT	16		 PBGSIT	37		 RBG CT	15, 16		 PBGSIT	37	
			 RBGIT CT	39					 RBG/RBG CT	15, 16, 39		 PBGSIT	27	
 KBG CT	36		 TBG	33		 PBG	27		 KBG CT	35				
			 TBG CT	34					 KBG CT	36				
									 TBG	33				
									 TBG CT	34				
			 RBU	28		 PBU	24		 RBU	28		 PBU	24	
						 IBU	40-41		 HBU	42		 IBU	40-41	
									 HBUP	42				
 RBU RBUP	11, 20, 21		 RBU RBUP	11, 20, 28-29, 21		 PBU	24		 RBU RBUP	11, 20, 28-29, 21		 PBU	24	
 RBU	28-29		 TBU	31-32		 IBU	40-41		 TBU	31-32		 IBU	40-41	
			 DBU	22					 DBU	22				

PFERD – Safe tools are our speciality

PFERD industrial power brushes meet a high quality and safety standard, which is constantly monitored and further developed in our own laboratories. As one of the leading manufacturers of brush tools, PFERD fulfils the requirements of European standard EN 1083.

Guidelines on the safe and economic use of PFERD brushes come with every packaging unit. They help you to increase your level of personal work safety.



Safety notes:



= Wear gloves!



= Wear hearing protection!



= Read the safety instructions!



= Wear a dust mask!



= Wear eye protection!

Use protective machine cover!

Maximum permitted rotational speed

In order to guarantee operating safety, the maximum permitted rotational speed indicated on the brush, label and in this catalogue must never be exceeded!

Please observe the following before use:

The tool drive speed must not exceed the maximum permitted brush speed.

Please refer to our product information and product tables for further recommendations regarding optimum operating speeds. These give details of the recommended rotational speeds [RPM] for an optimum working result

Brush diameter

In the case of hand-held tool drives, the brush diameter should never exceed 180 mm, regardless of the filament material.

Minimum arbor hole diameter in accordance with EN 1083

Depending on their total diameter (d_1), brushes must comply with the minimum arbor hole diameters ($d_{2\text{min}}$) listed below.

Total diameter d_1 of the brush [mm]	Minimum arbor hole diameter $d_{2\text{min}}$ [mm]
50	4.6
75	6.5
100	10
150	13
200	16
250	20
300	20
350	32

Conversion table [mm – inch]

Brush diameter		Arbor hole diameter		Face width		Filament diameter	
d_1 [mm]	d_1 [inch]	d_2 [mm]	d_2 [inch]	b [mm]	b [inch]	d_f [mm]	d_f [inch]
40	1–1/2	6.4	1/4	3	1/8	0.10	.004
50	2	9.5	3/8	6	1/4	0.15	.006
70	2–3/4	12.7	1/2	10	3/8	0.20	.008
76	3	15.9	5/8	13	1/2	0.25	.010
90	3–1/2	19.0	3/4	16	5/8	0.30	.012
100	4	22.2	7/8	19	3/4	0.35	.014
125	5	25.4	1	22	7/8	0.40	.016
150	6	28.6	1–1/8	25	1	0.45	.018
178	7	31.8	1–1/4	29	1–1/8	0.50	.020
200	8	38.1	1–1/2	32	1–1/4	0.55	.022
250	10	44.5	1–3/4	38	1–1/2	0.60	.023
300	12	50.8	2	50	2	0.65	.026
350	14	76.2	3	60	2–3/8	0.80	.032
380	15	107.9	4–1/4	75	3	0.90	.035
400	16	133.3	5–1/4	100	4	1.00	.039
						1.10	.040

Determining the recommended rotational speed

- 1 Select brush type
- 2 Read the recommended cutting speed
- 3 Determine the rotational speed using the brush diameter and cutting speed

The recommended cutting speed ranges [m/s] depend on the respective application and lie below the maximum permitted cutting speed.

1 Brush type	2 Cutting speed
End brushes	5–15 m/s
Cup brushes	15–45 m/s
Shank mounted wheel brushes	15–40 m/s
Wheel/bevel brushes with arbor hole/threaded	see diagram below

2 Recommended cutting speed [m/s] for wheel/bevel brushes with arbor hole/threaded

Application	[m/s]	10	15	20	25	30	35	40	45	50	55		
Deburring/ edge breaking	knotted											35–45 m/s	
													30–40 m/s
	crimped												25–40 m/s
													15–30 m/s
Removal of scale/ mill scale	knotted											35–55 m/s	
													30–40 m/s
Cleaning/ roughening of surfaces	knotted											35–40 m/s	
													30–35 m/s
	crimped												20–40 m/s
													15–35 m/s
Weld dressing	knotted											35–55 m/s	
													30–40 m/s
	crimped												30–45 m/s
													25–40 m/s

The colour bars correspond to the colour codes of the filament materials (see page 3).

3 Recommended rotational speed [RPM]

n [RPM]	Brush diameter d ₁ [mm]																	
	10	15	20	25	30	40	50	60	75	80	100	115	125	150	175	200	250	300
1,000	1	1	1	1	2	2	3	3	4	4	5	6	7	8	9	10	13	16
1,250	1	1	1	2	2	3	3	4	5	5	7	8	8	10	11	13	16	20
1,500	1	1	2	2	2	3	4	5	6	6	8	9	10	12	14	16	20	24
1,750	1	1	2	2	3	4	5	5	7	7	9	11	11	14	16	18	23	27
2,000	1	2	2	3	3	4	5	6	8	8	10	12	13	16	18	21	26	31
2,500	1	2	3	3	4	5	7	8	10	10	13	15	16	20	23	26	33	39
3,000	2	2	3	4	5	6	8	9	12	13	16	18	20	24	27	31	39	47
3,500	2	3	4	5	5	7	9	11	14	15	18	21	23	27	32	37	46	55
4,000	2	3	4	5	6	8	10	13	16	17	21	24	26	31	37	42	52	63
4,500	2	4	5	6	7	9	12	14	18	19	24	27	29	35	41	47	59	71
5,000	3	4	5	7	8	10	13	16	20	21	26	30	33	39	46	52	65	79
5,500	3	4	6	7	9	12	14	17	22	23	29	33	36	43	50	58	72	
6,000	3	5	6	8	9	13	16	19	24	25	31	36	39	47	55	63	79	
6,500	3	5	7	9	10	14	17	20	26	27	34	39	43	51	60	68		
7,000	4	5	7	9	11	15	18	22	27	29	37	42	46	55	64	73		
7,500	4	6	8	10	12	16	20	24	29	31	39	45	49	59	69	79		
8,000	4	6	8	10	13	17	21	25	31	34	42	48	52	63	73			
10,000	5	8	10	13	16	21	26	31	39	42	52	60	65	79				
12,000	6	9	13	16	19	25	31	38	47	50	63	72	79					
14,000	7	11	15	18	22	29	37	44	55	59	73							
16,000	8	13	17	21	25	34	42	50	63	67								
20,000	10	16	21	26	31	42	52	63	79									
22,000	12	17	23	29	35	46	58	69										
25,000	13	20	26	33	39	52	65	79										

Example:
RBG 11512 Steel
Cleaning surfaces
Brush dia. d₁: 115 mm
Cutting speed: 39 m/s
Rotational speed: 6,500 RPM

$$\text{Cutting speed (v)} = \frac{\varnothing (d_1) \times \pi \times \text{RPM (n)}}{1,000 \times 60}$$

Recommendations for use:

Brushing pressure and work position

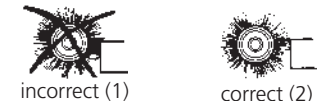

incorrect (1) correct (2)
Only use the filament tips (Fig. 2).

Exception

In the case of brushes with plastic filament material, it is not only the tips of the filament that can be used, but 2–3 mm of the bristle length. In the case of stationary brushes, machining should be carried out under the middle of the brush (see Fig. 2).

Visible trim lengths

Short visible trim lengths give a stiffer trim surface, resulting in more aggressive brushing action. Longer trim lengths are more flexible, giving a softer brush performance that produces a more uniform finish, even on non-homogeneous surfaces.

Self-sharpening effect

The self-sharpening effect can be improved by changing the brush operating direction.

Filament diameters

Thick filament

■ An aggressive brushing action with a coarse surface finish, as fewer filament tips are in contact with the surface of the workpiece at the same time

Thin filament

■ A soft brushing action with a fine surface finish, as many filament tips are in contact with the surface of the workpiece at the same time

■ Longer service life of the brush due to the higher level of flexibility of the filaments

Solutions to problems

Problems	Possible solutions
Inadequate brushing action	<ul style="list-style-type: none"> ■ Increase rotational speed or use larger brush diameter at unchanged rotational speed ■ Choose a brush with shorter trim ■ Use a brush with thicker filaments
Excessively strong brushing action	<ul style="list-style-type: none"> ■ Reduce rotational speed or use smaller brush diameter at unchanged rotational speed ■ Reduce the brushing pressure ■ Choose a brush with longer trim ■ Use a brush with thinner filaments
Surface is too rough and irregular	<ul style="list-style-type: none"> ■ Use a wider brush ■ Use a brush with thinner filaments ■ Reduce rotational speed
Excessively fine finish/surface appears too polished	<ul style="list-style-type: none"> ■ Select a brush with thicker filaments ■ Select a brush with shorter trim ■ Reduce rotational speed
Secondary burr formation	<ul style="list-style-type: none"> ■ Change brush-to-workpiece operating angle ■ Choose a brush with shorter trim ■ Use a brush with thicker filaments

Industrial power brushes

Filament materials and their application



Steel wire (ST) 	<p>PFERD uses special quality wires with high flexibility and bending fatigue strength as standard. In combination with the high filament density, these brushes have longer service lives than conventional brushes and therefore the processing costs per piece are reduced.</p> <p>In contrast to brushes with crimped wire, knotted brushes are produced with straight steel wire.</p>
Stainless steel wire (INOX) 	<p>In order to fulfil the particular requirements for machining stainless steel (INOX), PFERD uses a wire quality of 1.4310 (V2A) on all its INOX brushes.</p> <p>Practical experience gained from industrial use confirms that this wire quality achieves excellent corrosion resistance with optimum tool life.</p>
Brass wire (MES) 	<p>Brass wire is very soft in comparison to steel and stainless steel wire. It is mainly used for the machining of copper, brass and non-ferrous metals.</p>
Plastic filaments	<p>Selecting a suitable abrasive grain is crucial for the optimum solution of the different machining tasks. For the various applications and materials, PFERD offers industrial power brushes in the following filament types: silicon carbide (SiC), ceramic oxide (CO) and nylon (without grain).</p> <p>In the case of SiC and CO filament types, the abrasive grain is encapsulated into flexible plastic bristles. During the wearing of the carrier material, new abrasive grains are constantly released, which ensures the constant aggressive nature of the brush.</p> <p>Depending on the application, either round or rectangular filaments can be chosen. In the case of applications that require the brush to be especially abrasive, brushes with rectangular filaments (REC) are recommended. In the case of applications that require the brush to be especially flexible, brushes with round filaments are to be preferred.</p>
with silicon carbide abrasive grain (SiC) 	<p>PFERD offers grit sizes between 80 and 320 for the different machining tasks.</p>
with ceramic abrasive grain (CO) 	<p>Brushes with ceramic grain (CO) demonstrate a high level of toughness and very good cutting ability in comparison to types with silicon carbide or aluminium oxide. They are the correct choice if high stock removal and aggressive brushing is desired.</p>
without abrasive grain (nylon) 	<p>Due to the flexible filament material, brushes with nylon filament are less aggressive than brushes with wire or SiC/CO filament. They are particularly suitable for the machining of materials that would otherwise be "scratched" or damaged, e.g. soft plastic.</p>

Filament material	Material to be machined						
	Steel	Stainless steel (INOX)	Non-ferrous metals			Cast iron	Plastics
			Aluminium	Soft non-ferrous metals Brass, copper, zinc	Hard non-ferrous metals Titanium, bronze, nickel- and cobalt-based alloys		
Steel wire (ST)	●	–	–	–	–	●	○
Stainless steel wire (INOX)	○	●	●	○	○	–	–
Brass wire (MES)	–	–	–	●	–	–	–
Plastic filament							
with silicon carbide abrasive grain (SiC)	●	●	●	–	○	●	●
with ceramic abrasive grain (CO)	●	●	●	–	●	○	○
without abrasive grain (nylon)	–	–	○	○	–	–	●

● = highly suitable ○ = suitable – = not suitable

PFERD PRAXIS



PFERD PRAXIS brochures contain much valuable information on material properties, as well as tips and tricks on the use of PFERD tools.



PFERDVIDEO

You will receive more information here or at www.pferd.com

Due to its particularly good forming and welding qualities, its resistance to corrosion and its attractive appearance, stainless steel (INOX) is becoming increasingly popular for various products. These properties also place special requirements and demands on the brush used.

PFERD wire qualities

In order to fulfil the particular requirements for machining INOX, PFERD produces all stainless steel (INOX) brushes using stainless steel (INOX) of the quality 1.4310. Practical experience gained from industrial use confirms that this wire quality achieves excellent corrosion resistance with optimum tool life.

The wire quality of 1.4310 in INOX brushes tends to become ferromagnetic after cold working (can be attracted using magnets). The reason for this is a change in the microstructure caused through deformation (e.g. in wire drawing process). This change in microstructure and the resulting ferromagnetic qualities have no influence on the quality and corrosion resistance of the INOX wire. It retains its corrosion-resistant properties.

All PFERD brushes with INOX wire are colour-coded in blue and are suitable for use on all stainless steels (INOX), such as 1.4401 (V4A).

PFERD brushes in INOX-TOTAL type

PFERD offers a range of "INOX-TOTAL" (IT) brushes for the most demanding of operating conditions. These brushes have been specially developed for stainless steel work and are characterized by the fact that all brush parts are made from stainless steel of quality 1.4310 (V2A), ensuring optimum corrosion protection. Please refer to pages 37–39 for detailed information and ordering data.

Stainless steel (INOX) processing competence

PFERD provides a comprehensive range of tools which meets the demands for work on stainless steel (INOX). Our experienced sales representatives are happy to answer your questions. Please contact us.

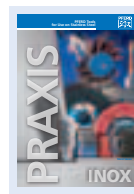
The PRAXIS brochure "PFERD tools for use on stainless steel (INOX)" contains much valuable information on material properties and application recommendations.



PFERDVIDEO
You will receive more information here or at www.pferd.com

INOX wire qualities in accordance with the standard

AISI	Short no. acc. to EN 10027-1	Material no. acc. to EN 10027-2
304	X5CrNi18-10	1.4301 (V2A)
301	X10CrNi18-8 (current standard)	1.4310 (V2A)
302	X12CrNi 17-7 (previous standard)	1.4310 (V2A)
316	X5CrNiMo17-12-2	1.4401 (V4A)
316	X3CrNiMo17-13-3	1.4436 (V4A)
316Ti	X6CrNiMoTi17-12-2	1.4571 (V4A)

Note

To avoid possible problems, it makes sense to run preliminary tests to check the corrosion resistance of the workpiece.

Finishing

General cleaning of the workpieces after brushing is recommended in order to prevent loose particles sticking to the workpiece. For workpieces that are used in a heavily corrosive environment, processing with grinding tools or etching or passivation is recommended. This also applies when not only stainless steels but also non-alloyed steels are processed and it cannot be completely ruled out that abrasion particles will land on the stainless steel. For detailed information and ordering data on grinding and polishing tools, please refer to Catalogue 204.

Avoiding corrosion when brushing INOX components

Cause of corrosion	Solution
Structure changes through too much heat build-up	Avoid heat build-up through: <ul style="list-style-type: none"> ■ Lower rotational speed ■ Reduced brushing pressure ■ Oscillating brushing
Since apart from the filament material all other brush parts are generally made of steel, corrosion can occur through contact between these parts with the workpiece. INOX-TOTAL brush types are an exception to this.	<ul style="list-style-type: none"> ■ Use INOX-TOTAL brushes ■ Avoid contact between the face plates and workpiece ■ Use end brushes with plastic coatings
Using the same tool for work on steel and stainless steel (INOX) workpieces	<ul style="list-style-type: none"> ■ Do not use brushes which have already been used on steel, copper or other metals ■ Do not process steel near stainless steel (INOX) applications
Wire particle residues in the surface (crevice corrosion)	<ul style="list-style-type: none"> ■ Avoid a high brushing pressure ■ Select a low rotational speed
Stock removal rate is too low	Removal of structural changes by: <ul style="list-style-type: none"> ■ Extending brushing time ■ Using grinding tools

Industrial power brushes

Well packed and presented



Industrial packaging

PFERD offers industrial power brushes in industrial packaging as standard.



All brushes in industrial packaging (IP) are marked with this pictogram throughout this catalogue.

Advantages:

- Robust protective packaging
- Packaging label stating all the important information, such as article number, description, EAN code and technical information
- Guidelines for safe use of brushes included in every packaging



POS packaging

Wheel, cup, end and bevel brushes are provided by PFERD in individual promotional packaging. They can be presented highly effectively using the PFERD TOOL-CENTER, the point of sale from PFERD. Individually packaged shank mounted brushes are supplied in the practical outer carton.



All brushes in POS packaging are marked with this pictogram and the addition of "POS" in the description throughout this catalogue.

Advantages:

- Functional European standard hole pattern mounting for optimum product presentation on the sales wall
- Packaging label stating all the important information, such as article number, description, EAN code and technical information
- Product is easily recognizable through the viewing window

An overview of all brushes in POS packaging can be found on pages 47–48.



Brush sets

PFERD offers three brush sets in a promotional counter display carton. They can be effectively placed in the smallest of spaces.

For brush sets, see page 31.



PFERD TOOL-CENTER

All brushes in POS packaging can be superbly presented using the PFERD TOOL-CENTER.

On the TOOL-CENTER, users will find all the important information required in order to select the most appropriate tool. The information and symbol cards also contain useful tips relating to the correct use of PFERD tools.

















You will find more information on the PFERD TOOL-CENTER in our brochure "The PFERD TOOL-CENTER – More turnover for you at the point of sale".











Packaging label

Advantages:

- Pictograms for clarification of the most important product features
- Information regarding the safe and best use of brushes



Brush diameter d_1 [mm]	
	Wheel brushes crimped/knotted
	
	Shank mounted wheel brushes crimped/knotted
	
	Shank mounted bevel and cup brushes crimped
	
	Shank mounted end brushes crimped/knotted
	
	Threaded cup brushes crimped/knotted
	
	Threaded bevel brushes crimped/knotted
	
	Disc brushes/ tube brushes
	

Face width b [mm]	
	Wheel brushes crimped/knotted
	
Mounting type	
	Arbor hole/shank
	
	Thread
	
Filament diameter d_6 [mm]	
	Filament diameter d_6
Overall length l_1 [mm]	
	Tube brushes/ Scratch brushes
	
No. of rows Z	
	Scratch brushes



Excellent for medium-duty hand-held or automated brushing of workpieces with large surfaces.

Recommendations for use:

- Work with low contact pressure
- Use only the filament tips
- Can be used with all common stationary drive machines and bench grinders due to variable arbor hole diameter
- Please see page 8 for information on selecting the correct abrasive grain

Ordering note:

Please order adapter set AK 32 separately.

RBU = Wheel brushes, crimped, narrow face

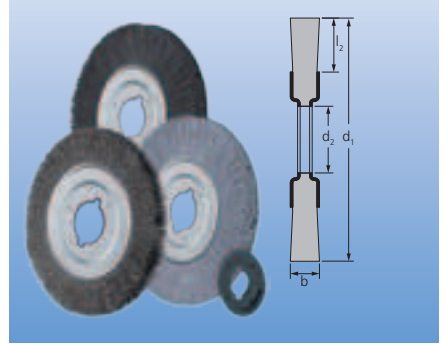

Description	Packaging	Brush dia. d ₁ [mm]	Face width b [mm]	Trim length l ₂ [mm]	Incl. adapter	Max. arbor hole dia. d ₂ [mm]	Fila-ment dia. d ₆ [mm]	Rec. speed [RPM]	Max. perm. speed [RPM]
	 EAN 4007220								
Steel wire (ST)									
RBU 10012/14,0 ST 0,15	597866	100	12	24	-	14.0	0.15	4,000–6,000	8,000
RBU 10012/14,0 ST 0,30	597873	100	12	24	-	14.0	0.30	4,000–6,000	8,000
RBU 12512/14,0 ST 0,30	806791	125	12	32	-	14.0	0.30	4,000–6,000	8,000
RBU 15012/22,2 ST 0,25	530412	150	12	28	22.2	31.8	0.25	3,000–4,500	6,000
RBU 18012/22,2 ST 0,30	658734	180	12	43	22.2	31.8	0.30	3,000–4,500	6,000
RBU 20016/22,2 ST 0,25	530436	200	16	44	22.2	31.8	0.25	3,000–4,500	6,000
RBU 25020/22,2 ST 0,25	530443	250	20	70	22.2	31.8	0.25	1,800–2,700	3,600
Stainless steel wire (INOX)									
All INOX brushes are degreased.									
RBU 12512/14,0 INOX 0,30	806807	125	12	32	-	14.0	0.30	3,200–5,200	8,000
RBU 15012/22,2 INOX 0,30	597880	150	12	28	22.2	31.8	0.30	2,400–3,900	6,000
RBU 18012/22,2 INOX 0,30	658796	180	12	43	22.2	31.8	0.30	2,400–3,900	6,000
RBU 20016/22,2 INOX 0,30	597910	200	16	44	22.2	31.8	0.30	2,400–3,900	6,000
RBU 25020/22,2 INOX 0,30	597927	250	20	70	22.2	31.8	0.30	1,400–2,300	3,600
Plastic filament silicon carbide (SiC)									
RBU 10012/12,0 SiC 80 1,00	597903	100	12	22	-	12.0	1.00	3,200–5,200	8,000
RBU 10012/12,0 SiC 180 0,90	220870	100	12	22	-	12.0	0.90	3,200–5,200	8,000
RBU 15016/12,0 SiC 80 1,00	530467	150	16	32	12.0	31.8	1.00	2,400–3,900	8,000
RBU 15016/12,0 SiC 180 0,90	220894	150	16	32	12.0	31.8	0.90	2,400–3,900	8,000
RBU 20016/22,2 SiC 80 1,00	530474	200	16	32	22.2	31.8	1.00	1,800–2,900	4,500
RBU 20016/22,2 SiC 180 0,90	220917	200	16	32	22.2	31.8	0.90	1,800–2,900	4,500
RBU 25016/22,2 SiC 80 1,00	530481	250	16	38	22.2	31.8	1.00	1,400–2,300	3,600
RBU 25016/22,2 SiC 180 0,90	220948	250	16	38	22.2	31.8	0.90	1,400–2,300	3,600
Plastic filament ceramic grain (CO)									
RBU 10012/12,0 CO 120 1,10	837269	100	12	22	-	12.0	1.10	3,200–5,200	8,000
RBU 15016/12,0 CO 120 1,10	837276	150	16	28	12.0	31.8	1.10	2,400–3,900	6,000
RBU 20016/22,2 CO 120 1,10	837283	200	16	38	22.2	31.8	1.10	1,800–2,900	4,500
Plastic filament nylon									
RBU 10012/12,0 Nylon 0,40	899298	100	12	22	-	12.0	0.40	3,200–5,200	8,000
RBU 15016/12,0 Nylon 0,40	899304	150	16	32	12.0	31.8	0.40	3,200–5,200	8,000
RBU 20016/22,2 Nylon 0,40	899311	200	16	32	22.2	31.8	0.40	2,400–3,900	6,000

Additional crimped filament wheel brushes with arbor hole for stationary use can be found on pages 20–21.

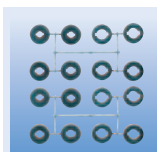

Adapter set AK 32
(EAN 4007220608593)
Arbor hole diameters contained in the set in mm (inch): 20 / 18 / 14 / 12 / 25.4 (1) / 22.2 (7/8) / 16 (5/8) / 12.7 (1/2). **Note:** Wheel brushes with diameters 100 and 125 mm cannot be used with adapter set AK 32.



Arbor BO 8/12-22.2 5-18
(EAN 4007220751923)
For all narrow face wheel brushes up to diameter 150 mm with arbor hole.

Safety note: Arbors must only be used for brush diameters up to a maximum of 150 mm.

For more information:
For detailed information and ordering data on matching adapter sets and arbors, please refer to pages 44–46.

Wheel brushes

Wheel brushes, crimped

RBU = Wheel brushes, crimped, wide face, general purpose

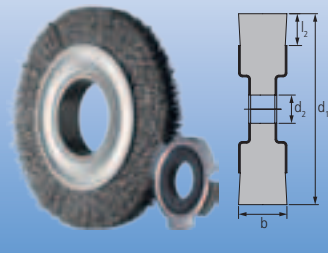

Excellent for medium-duty hand-held or automated brushing of workpieces with large surfaces. Developed for versatile use in the workshop.

Ordering example:

EAN 4007220956236
POS RBU 10020/14.0 ST 0.30

Recommendations for use:

- Work with low contact pressure
- Use only the wire tips
- Can be used with all common stationary drive machines and bench grinders due to variable arbor hole diameter

Description	Packaging	Brush dia. d ₁ [mm]	Face width b [mm]	Trim length l ₁ [mm]	Incl. adapter	Max. arbor hole dia. d ₂ [mm]	Fila-ment dia. d ₆ [mm]	Rec. speed [RPM]	Max. perm. speed [RPM]
	 EAN 4007220								
Steel wire (ST)									
POS RBU 10020/14,0 ST 0,30	956236	100	20	25	12/14/18/22.2/25.4	30.0	0.30	4,000–6,000	8,000
POS RBU 10028/14,0 ST 0,30	956243	100	28	25	12/14/18/22.2/25.4	30.0	0.30	4,000–6,000	8,000
POS RBU 12520/14,0 ST 0,30	956250	125	20	30	12/14/18/22.2/25.4	30.0	0.30	3,000–4,500	6,000
POS RBU 12528/14,0 ST 0,30	956274	125	28	30	12/14/18/22.2/25.4	30.0	0.30	3,000–4,500	6,000
POS RBU 15025/AK32-2 ST 0,20	956281	150	25	25	AK 32-2	50.8	0.20	3,000–4,500	6,000
POS RBU 15025/AK32-2 ST 0,30	956304	150	25	25	AK 32-2	50.8	0.30	3,000–4,500	6,000
POS RBU 15038/AK32-2 ST 0,20	956298	150	38	25	AK 32-2	50.8	0.20	3,000–4,500	6,000
POS RBU 15038/AK32-2 ST 0,30	956311	150	38	25	AK 32-2	50.8	0.30	3,000–4,500	6,000
POS RBU 18025/AK32-2 ST 0,20	956335	180	25	40	AK 32-2	50.8	0.20	3,000–4,500	6,000
POS RBU 18025/AK32-2 ST 0,30	956342	180	25	40	AK 32-2	50.8	0.30	3,000–4,500	6,000
POS RBU 18038/AK32-2 ST 0,30	956359	180	38	40	AK 32-2	50.8	0.30	3,000–4,500	6,000
POS RBU 20025/AK32-2 ST 0,20	956366	200	25	50	AK 32-2	50.8	0.20	2,300–3,400	4,500
POS RBU 20025/AK32-2 ST 0,30	956373	200	25	50	AK 32-2	50.8	0.30	2,300–3,400	4,500
POS RBU 20038/AK32-2 ST 0,30	956380	200	38	50	AK 32-2	50.8	0.30	2,300–3,400	4,500
Stainless steel wire (INOX)									
POS RBU 10020/14,0 INOX 0,30	956397	100	20	25	12/14/18/22.2/25.4	30.0	0.30	3,200–5,200	8,000
POS RBU 10028/14,0 INOX 0,30	956403	100	28	25	12/14/18/22.2/25.4	30.0	0.30	3,200–5,200	8,000
POS RBU 12520/14,0 INOX 0,30	956410	125	20	30	12/14/18/22.2/25.4	30.0	0.30	2,400–3,900	6,000
POS RBU 12528/14,0 INOX 0,30	956434	125	28	30	12/14/18/22.2/25.4	30.0	0.30	2,400–3,900	6,000
POS RBU 15025/AK32-2 INOX 0,20	956441	150	25	25	AK 32-2	50.8	0.20	2,400–3,900	6,000
POS RBU 15025/AK32-2 INOX 0,30	956465	150	25	25	AK 32-2	50.8	0.30	2,400–3,900	6,000
POS RBU 15038/AK32-2 INOX 0,20	956458	150	38	25	AK 32-2	50.8	0.20	2,400–3,900	6,000
POS RBU 15038/AK32-2 INOX 0,30	956472	150	38	25	AK 32-2	50.8	0.30	2,400–3,900	6,000
POS RBU 18025/AK32-2 INOX 0,20	956489	180	25	40	AK 32-2	50.8	0.20	2,400–3,900	6,000
POS RBU 18025/AK32-2 INOX 0,30	956496	180	25	40	AK 32-2	50.8	0.30	2,400–3,900	6,000
POS RBU 18038/AK32-2 INOX 0,30	956502	180	38	40	AK 32-2	50.8	0.30	2,400–3,900	6,000
POS RBU 20025/AK32-2 INOX 0,20	956519	200	25	50	AK 32-2	50.8	0.20	1,800–2,900	4,500
POS RBU 20025/AK32-2 INOX 0,30	956526	200	25	50	AK 32-2	50.8	0.30	1,800–2,900	4,500
POS RBU 20038/AK32-2 INOX 0,30	956533	200	38	50	AK 32-2	50.8	0.30	1,800–2,900	4,500

Additional crimped filament wheel brushes with arbor hole for stationary use can be found on pages 20–21.



POS packaging
Individual promotional packaging for the PFERD TOOL-CENTER. For the entire range of brushes in POS packaging, please refer to pages 47–48.



IP packaging
Robust industrial packaging.



Adapter set AK 32-2
(EAN 4007220806890)
Arbor hole diameters contained in the set in mm (inch): 31.75 / 20 / 18 / 14 / 12 / 25.4 (1) / 22.2 (7/8) / 19.2 (.750) / 16 (5/8) / 12.7 (1/2). Included in the delivery with wheel brushes having diameter 150–200 mm. **Note:** Adapter pairs AM 51 can also be used for applications with high heat generation and application of force. **Exception:** Wheel brushes with diameters 100 and 125 mm cannot be used with adapter pairs AM 51.

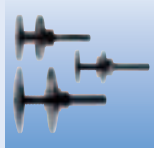

Arbor
BO 8/12-22.2 5-18
For RBU 10020 and 12520
BO 8/22.2 5-10
For RBU 10028 and 12528
BO 12/22.2 10-30
For RBU 15025 and 15038

Safety note:
Arbors must only be used for brush diameters up to a maximum of 150 mm.

For more information:
For detailed information and ordering data on matching adapter sets and arbors, please refer to pages 44–46.



Excellent for medium-duty hand-held or automated brushing of workpieces with large surfaces. Developed specially for industrial use.

Advantages:

- Long tool life and aggressive brushing action due to special quality wires and extremely high filament density.

Recommendations for use:

- Work with low contact pressure
- Use only the wire tips
- Can be used with all common stationary drive machines and bench grinders due to variable arbor hole diameter

Ordering example:

EAN 4007220**658710**
 RBU 10020/14.0 ST 0.30

RBU = Wheel brushes, crimped, wide face, industrial use

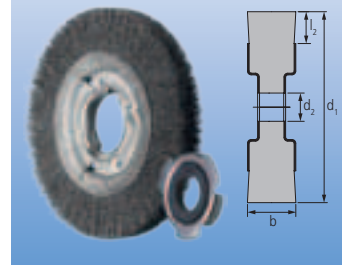

Description	Packaging	Brush dia. d ₁ [mm]	Face width b [mm]	Trim length l ₂ [mm]	Incl. adapter	Max. arbor hole dia. d ₂ [mm]	Fila-ment dia. d ₅ [mm]	Rec. speed [RPM]	Max. perm. speed [RPM]
	 EAN 4007220								
Steel wire (ST)									
RBU 10020/14,0 ST 0,30	658710	100	20	24	14.0/18.0/22.2	25.4	0.30	4,000–6,000	8,000
RBU 10028/14,0 ST 0,30	153604	100	28	24	14.0/18.0/22.2	25.4	0.30	4,000–6,000	8,000
RBU 12520/14,0 ST 0,30	806852	125	20	30	14.0/18.0/22.2	25.4	0.30	4,000–6,000	8,000
RBU 12528/14,0 ST 0,30	806869	125	28	30	14.0/18.0/22.2	25.4	0.30	4,000–6,000	8,000
RBU 15025/AK32-2 ST 0,30	658727	150	25	25	AK 32-2	50.8	0.30	3,000–4,500	6,000
RBU 15038/AK32-2 ST 0,30	153628	150	38	25	AK 32-2	50.8	0.30	3,000–4,500	6,000
RBU 18025/AK32-2 ST 0,30	658741	180	25	40	AK 32-2	50.8	0.30	3,000–4,500	6,000
RBU 20025/AK32-2 ST 0,30	658765	200	25	38	AK 32-2	50.8	0.30	2,300–3,400	4,500
RBU 20038/AK32-2 ST 0,30	153635	200	38	38	AK 32-2	50.8	0.30	2,300–3,400	4,500
RBU 25030/AK32-2 ST 0,30	658772	250	30	50	AK 32-2	50.8	0.30	1,800–2,700	3,600
RBU 25048/AK32-2 ST 0,30	220924	250	48	50	AK 32-2	50.8	0.30	1,800–2,700	3,600
RBU 30040/50,8 ST 0,30	616086	300	40	40	50.8	117.5	0.30	1,500–2,500	3,000

Stainless steel wire (INOX)

All INOX brushes are degreased.

RBU 12520/14,0 INOX 0,30	806876	125	20	30	14.0/18.0/22.2	25.4	0.30	3,200–5,200	8,000
RBU 12528/14,0 INOX 0,30	806883	125	28	30	14.0/18.0/22.2	25.4	0.30	3,200–5,200	8,000
RBU 15025/AK32-2 INOX 0,30	658789	150	25	25	AK 32-2	50.8	0.30	2,400–3,900	6,000
RBU 15038/AK32-2 INOX 0,30	220887	150	38	25	AK 32-2	50.8	0.30	2,400–3,900	6,000
RBU 18025/AK32-2 INOX 0,30	658871	180	25	40	AK 32-2	50.8	0.30	2,400–3,900	6,000
RBU 20025/AK32-2 INOX 0,30	658895	200	25	38	AK 32-2	50.8	0.30	1,800–2,900	4,500
RBU 20038/AK32-2 INOX 0,30	220900	200	38	38	AK 32-2	50.8	0.30	1,800–2,900	4,500
RBU 25030/AK32-2 INOX 0,30	658901	250	30	50	AK 32-2	50.8	0.30	1,400–2,300	3,600
RBU 25048/AK32-2 INOX 0,30	220931	250	48	50	AK 32-2	50.8	0.30	1,400–2,300	3,600

Additional crimped filament wheel brushes with arbor hole for stationary use can be found on pages 20–21.

Adapter set AK 32-2
 (EAN 4007220**806890**)
 Arbor hole diameters contained in the set in mm (inch): 31.75 / 20 / 18 / 14 / 12 / 25.4 (1) / 22.2 (7/8) / 19.2 (.750) / 16 (5/8) / 12.7 (1/2). Included in the delivery with wheel brushes having diameter 150–250 mm.

Note:
Adapter pairs AM 51 can also be used on applications with high heat generation and applications of force. **Exception:** Wheel brushes with diameters 100 and 125 mm cannot be used with adapter pairs AM 51. The use of wheel brushes with a diameter of 300 mm is possible with adapter pairs AM 51.

Arbor
BO 8/12-22.2 5-18
 For RBU 10020 and 12520
BO 8/22.2 5-10
 For RBU 10028 and 12528
BO 12/22.2 10-30
 For RBU 15025 and 15038

Safety note:
 Arbors must only be used for brush diameters up to a maximum of 150 mm.

For more information:
 For detailed information and ordering data on matching adapter sets and arbors, please refer to pages 44–46.

Wheel brushes

Wheel brushes, crimped

RBU = Wheel brushes, crimped, for use on angle grinders

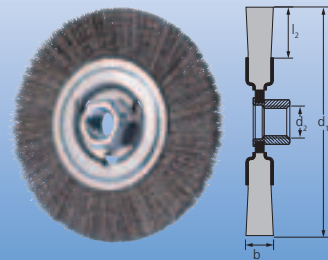

Suitable for medium-duty brushing such as scale removal, rust removal, cleaning of weld seams and light deburring. Crimped wire enables more flexible working and produces smooth surfaces.

Recommendations for use:

- Suitable for use on angle grinders
- For optimum performance, use speed-adjustable angle grinders

Ordering example:

EAN 4007220**806968**
POS RBU 11512/M14 ST 0.30



Description	Packaging	Brush dia. d ₁ [mm]	Face width b [mm]	Trim length l ₂ [mm]	Thread d ₂	Filament dia. d ₆ [mm]	Rec. speed [RPM]	Max. perm. speed [RPM]
	 EAN 4007220							

Steel wire (ST)

POS RBU 11512/M14 ST 0,30	806968	115	12	25	M14x2	0.30	6,300–12,500	12,500
POS RBU 12512/M14 ST 0,30	806975	125	12	15	M14x2	0.30	5,500–11,000	11,000

Stainless steel wire (INOX)

All INOX brushes are degreased.

POS RBU 11512/M14 INOX 0,30	806982	115	12	25	M14x2	0.30	5,000–12,500	12,500
POS RBU 12512/M14 INOX 0,30	806999	125	12	15	M14x2	0.30	4,400–11,000	11,000

Brushes with other threads are available on request.

RBU = Wheel brushes, crimped, POLISCRATCH type

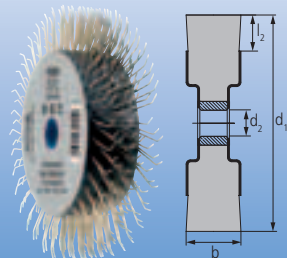

Excellent for processing and removing soft materials such as underseal and anti drumming compound. Most suitable for achieving rough, like sandblasted, surfaces due to the specific geometry of the filament material.

Advantages:

- High cooling effect and no smearing or loading of the brush due to the open construction of the filament material
- Long tool life as the brush can be re-sharpened using a sharpening tool

Recommendations for use:

- Suitable for use on adjustable angle grinders and straight grinders

Ordering example:

EAN 4007220**892459**
POS RBU 10020/M14 SC ST 0.60

PFERDERGONOMICS®:



Description	Packaging	Brush dia. d ₁ [mm]	Face width b [mm]	Trim length l ₂ [mm]	Thread d ₂	Filament dia. d ₆ [mm]	Rec. speed [RPM]	Max. perm. speed [RPM]
	 EAN 4007220							

Steel wire (ST)

POS RBU 10020/M14 SC ST 0,60	892459	100	20	18	M14x2	0.60	1,200–3,500	6,000
------------------------------	--------	-----	----	----	-------	------	-------------	-------



POS packaging

Individual promotional packaging for the PFERD TOOL-CENTER. For the entire range of brushes in POS packaging, please refer to pages 47–48.



IP packaging

Robust industrial packaging.

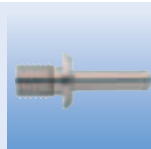

Arbor BO 8/M14

(EAN 4007220**900482**)

For mounting POLISCRATCH brushes on straight grinders, flexible shafts or power drills.

Safety note:

Use exclusively with POLISCRATCH brushes.

For more information:

For detailed information and ordering data on matching adapter sets and arbors, please refer to pages 44–46.



Sharpening block DSB

POLISCRATCH brushes can be re-sharpened up to ten times.

To do this, please press the filament tips onto a grinding stone for around 2–3 seconds. For this, the filament tips must point counter to the direction of tool rotation.

Further information and ordering data for sharpening block DSB can be found in Catalogue 206.



Aggressively working brush. For heavy-duty brushing in metalwork, such as descaling, rust removal, deburring, cleaning of weld seams and removal of adhesive residues.

Recommendations for use:

- Optimum results with high-performance angle grinders

Ordering example:

EAN 4007220**153512**

POS RBG 11512/22.2 ST 0.50

For the 10-piece packaging unit, please specify the description without "POS".

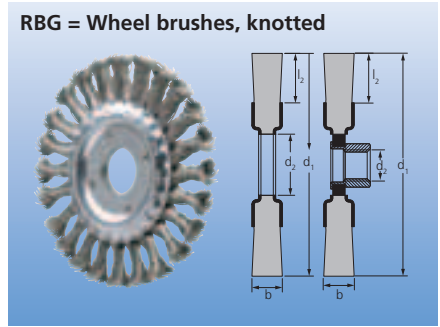

Description	Packaging		Brush dia. d ₁ [mm]	Face width b [mm]	Trim length l ₂ [mm]	Arbor hole dia./thread d ₂ [mm]	Filament dia. d ₆ [mm]	No. of knots	Rec. speed [RPM]	Max. perm. speed [RPM]
	EAN 4007220									

Steel wire (ST)

POS RBG 10012/M14 ST 0,50	658970	-	100	12	28	M14x2	0.50	22	10,000–15,000	20,000
POS RBG 11512/22,2 ST 0,50	153512	954966	115	12	22	22.2	0.50	24	6,300–12,500	12,500
POS RBG 11512/M14 ST 0,50	658987	-	115	12	22	M14x2	0.50	24	6,300–12,500	12,500
POS RBG 12512/22,2 ST 0,50	530597	952702	125	12	28	22.2	0.50	24	5,500–11,000	11,000
POS RBG 12512/M14 ST 0,50	658994	-	125	12	28	M14x2	0.50	24	5,500–11,000	11,000
POS RBG 15013/22,2 ST 0,60	597996	-	150	13	26	22.2	0.60	30	5,000–10,000	10,000
POS RBG 17813/22,2 ST 0,50	153413	954973	178	13	38	22.2	0.50	30	4,500–8,500	9,000
POS RBG 17813/M14 ST 0,50	659007	-	178	13	38	M14x2	0.50	30	4,500–8,500	9,000
POS RBG 17813/22,2 ST 0,80	578940	-	178	13	38	22.2	0.80	30	4,500–8,500	9,000

Stainless steel wire (INOX)

All INOX brushes are degreased.

POS RBG 11512/22,2 INOX 0,35	220795	954980	115	12	22	22.2	0.35	24	5,000–12,500	12,500
POS RBG 11512/M14 INOX 0,35	659014	-	115	12	22	M14x2	0.35	24	5,000–12,500	12,500
POS RBG 12512/22,2 INOX 0,35	530788	954997	125	12	28	22.2	0.35	24	4,400–11,000	11,000
POS RBG 12512/M14 INOX 0,35	659021	-	125	12	28	M14x2	0.35	24	4,400–11,000	11,000
POS RBG 17813/22,2 INOX 0,35	220733	955000	178	13	38	22.2	0.35	30	3,600–8,500	9,000
POS RBG 17813/M14 INOX 0,35	659038	-	178	13	38	M14x2	0.35	30	3,600–8,500	9,000

Brushes with other threads are available on request.



Arbor
BO 8/22.2 5-10
 (EAN 4007220**751930**)
 For all knotted wheel brushes up to diameter 125 mm with arbor hole diameter 22.2 mm.

BO 12/22.2 10-30 (EAN 4007220**561317**)
 For all knotted wheel brushes with diameter 150 mm and arbor hole diameter 22.2 mm.

Safety note:
 Arbors must only be used for brush diameters up to a maximum of 150 mm.

For more information:
 For detailed information and ordering data on matching adapter sets and arbors, please refer to pages 44–46.

Wheel brushes

Wheel brushes, knotted

RBG CT = Wheel brushes, knotted, COMBITWIST® type

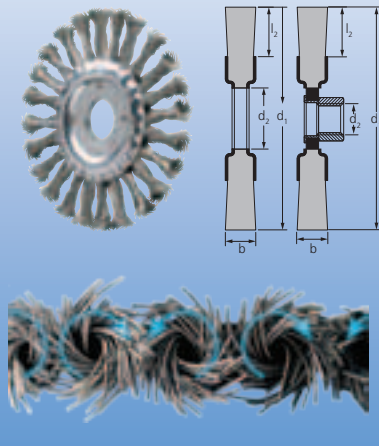

Aggressively working brush. For heavy-duty brushing in metalwork such as descaling, rust removal, deburring, cleaning of weld seams and removal of adhesive residues.

Advantages:

- Smooth operation, even on corners and edges
- No recoiling of the brush when used on edges
- Enhanced tool life
- Increased stock removal rate
- Reduced likelihood of the knotting becoming "unravalled" in use

Recommendations for use:

- Optimum results with high-performance angle grinders

Ordering example:

EAN 4007220**593356**

POS RBG 11512/22.2 CT ST 0.50

For the 10-piece packaging unit, please specify the description without "POS".



PFERDERGONOMICS®:



Description	Packaging		Brush dia. d ₁ [mm]	Face width b [mm]	Trim length l ₂ [mm]	Arbor hole dia./thread d ₂ [mm]	Filament dia. d ₀ [mm]	No. of knots	Rec. speed [RPM]	Max. perm. speed [RPM]
	1	10								
	EAN 4007220									
Steel wire (INOX) – COMBITWIST® type										
POS RBG 11512/22,2 CT ST 0,50	593356	955017	115	12	22	22.2	0.50	24	6,300–12,500	12,500
POS RBG 11512/M14 CT ST 0,50	806814	-	115	12	22	M14x2	0.50	24	6,300–12,500	12,500
POS RBG 12512/22,2 CT ST 0,50	593363	955024	125	12	28	22.2	0.50	24	5,500–11,000	11,000
POS RBG 12512/M14 CT ST 0,50	806821	-	125	12	28	M14x2	0.50	24	5,500–11,000	11,000
POS RBG 17813/22,2 CT ST 0,50	593370	955031	178	13	38	22.2	0.50	30	4,500–8,500	9,000
POS RBG 17813/22,2 CT ST 0,80	593394	-	178	13	38	22.2	0.80	30	4,500–8,500	9,000

Stainless steel wire (INOX) – COMBITWIST® type

All INOX brushes are degreased.

POS RBG 11512/22,2 CT INOX 0,35	593400	955048	115	12	22	22.2	0.35	24	5,000–12,500	12,500
POS RBG 11512/M14 CT INOX 0,35	806838	-	115	12	22	M14x2	0.35	24	5,000–12,500	12,500
POS RBG 12512/22,2 CT INOX 0,35	593417	955055	125	12	28	22.2	0.35	24	4,400–11,000	11,000
POS RBG 12512/M14 CT INOX 0,35	806845	-	125	12	28	M14x2	0.35	24	4,400–11,000	11,000
POS RBG 17813/22,2 CT INOX 0,35	593424	955062	178	13	38	22.2	0.35	30	3,600–8,500	9,000

Brushes with other threads are available on request.



POS packaging

Individual promotional packaging for the PFERD TOOL-CENTER. For the entire range of brushes in POS packaging, please refer to pages 47–48.



IP packaging

Robust industrial packaging.



Arbor BO 8/22.2 5-10

(EAN 4007220**751930**)

For all knotted wheel brushes up to diameter 125 mm with arbor hole diameter 22.2 mm.

Safety note:

Arbors must only be used for brush diameters up to a maximum of 150 mm.

For more information:

For detailed information and ordering data on matching adapter sets and arbors, please refer to pages 44–46.



PFERDVIDEO

You will receive more information here or at www.pferd.com



An aggressive and robust brush that is able to withstand high mechanical loads. Perfect for heavy-duty brushing in pipeline and container construction. This extra slim brush design is ideal for work in hard-to-reach places e.g. root weld seams.

Recommendations for use:

- Optimum results with high-performance angle grinders

Ordering example:

EAN 4007220750810
RBG 10006/16.0 PIPE ST 0.50

RBG PIPE = Wheel brushes, knotted, pipeline

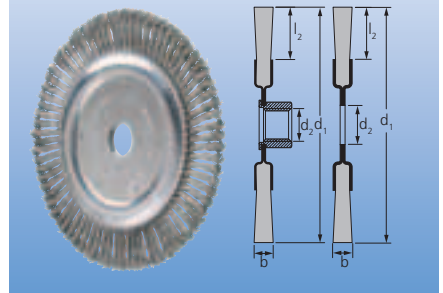

Description	Packaging	Brush dia. d_1 [mm]	Face width b [mm]	Trim length l_2 [mm]	Arbor hole dia./thread d_2 [mm]	No. of knots	Fila-ment dia. d_f [mm]	Rec. speed [RPM]	Max. perm. speed [RPM]
	 EAN 4007220								

Steel wire (ST)

RBG 10006/16,0 PIPE ST 0,50	750810	100	6	19	16.0	32	0.50	10,000–15,000	20,000
RBG 10006/M14 PIPE ST 0,50	750872	100	6	19	M14x2	32	0.50	10,000–15,000	20,000
RBG 11506/22,2 PIPE ST 0,50	750926	115	6	21	22.2	36	0.50	6,300–12,500	12,500
RBG 11506/M14 PIPE ST 0,50	750933	115	6	21	M14x2	36	0.50	6,300–12,500	12,500
RBG 12506/22,2 PIPE ST 0,50	750957	125	6	18	22.2	48	0.50	5,500–11,000	11,000
RBG 12506/M14 PIPE ST 0,50	750995	125	6	18	M14x2	48	0.50	5,500–11,000	11,000
RBG 15006/22,2 PIPE ST 0,50	751015	150	6	27	22.2	56	0.50	5,000–10,000	10,000
RBG 15006/M14 PIPE ST 0,50	751022	150	6	27	M14x2	56	0.50	5,000–10,000	10,000
RBG 17806/22,2 PIPE ST 0,50 56Z	751077	178	6	28	22.2	56	0.50	4,500–8,500	9,000
RBG 17806/M14 PIPE ST 0,50 56Z	751084	178	6	28	M14x2	56	0.50	4,500–8,500	9,000
RBG 17806/22,2 PIPE ST 0,50 76Z	751107	178	6	28	22.2	76	0.50	4,500–8,500	9,000
RBG 17806/M14 PIPE ST 0,50 76Z	751114	178	6	28	M14x2	76	0.50	4,500–8,500	9,000

Stainless steel wire (INOX)

All INOX brushes are degreased.

RBG 10006/16,0 PIPE INOX 0,50	751220	100	6	19	16.0	32	0.50	8,000–15,000	20,000
RBG 10006/M14 PIPE INOX 0,50	751237	100	6	19	M14x2	32	0.50	8,000–15,000	20,000
RBG 11506/22,2 PIPE INOX 0,50	751275	115	6	21	22.2	36	0.50	5,000–12,500	12,500
RBG 11506/M14 PIPE INOX 0,50	751305	115	6	21	M14x2	36	0.50	5,000–12,500	12,500
RBG 12506/22,2 PIPE INOX 0,50	751329	125	6	18	22.2	48	0.50	4,400–11,000	11,000
RBG 12506/M14 PIPE INOX 0,50	751343	125	6	18	M14x2	48	0.50	4,400–11,000	11,000
RBG 15006/22,2 PIPE INOX 0,50	751367	150	6	27	22.2	56	0.50	4,000–10,000	10,000
RBG 15006/M14 PIPE INOX 0,50	751374	150	6	27	M14x2	56	0.50	4,000–10,000	10,000
RBG 17806/22,2 PIPE INOX 0,50 76Z	751398	178	6	28	22.2	76	0.50	3,600–8,500	9,000
RBG 17806/M14 PIPE INOX 0,50 76Z	751404	178	6	28	M14x2	76	0.50	3,600–8,500	9,000

Brushes with other threads are available on request.



For tools specially suited to pipeline construction, see the brochure "PFERD tools for pipeline construction".



For detailed information and ordering data on PFERD reinforced grinding wheels for pipeline construction, please refer to Catalogue 206.

Wheel brushes

Wheel brushes pipeline



RBG PIPE CT = Wheel brushes, knotted, pipeline, COMBITWIST® type

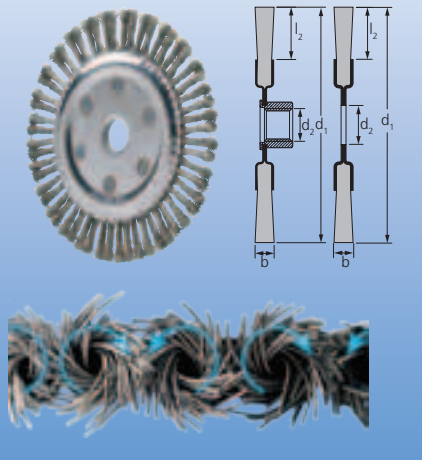

An aggressive and robust brush that is able to withstand high mechanical loads. Perfect for heavy-duty brushing in pipeline and container construction. This extra slim brush design is ideal for work in hard-to-reach places e.g. root weld seams.

Advantages:

- Smooth operation, even on corners and edges
- No recoiling of the brush when used on edges
- Enhanced tool life
- Increased stock removal rate
- Reduced likelihood of the knotting becoming "unravalled" in use

Recommendations for use:

- Optimum results with high-performance angle grinders

Ordering example:

EAN 4007220751138
RBG 17806/22.2 PIPE CT ST 0.50 56Z

PFERDERGONOMICS®:



Description	Packaging	Brush dia. d ₁ [mm]	Face width b [mm]	Trim length l ₂ [mm]	Abor hole dia./thread d ₂ [mm]	No. of knots	Fila-ment dia. d ₆ [mm]	Rec. speed [RPM]	Max. perm. speed [RPM]
	 EAN 4007220								

Steel wire (INOX) – COMBITWIST® type

RBG 17806/22,2 PIPE CT ST 0,50 56Z	751138	178	6	28	22.2	56	0.50	4,500–8,500	9,000
RBG 17806/M14 PIPE CT ST 0,50 56Z	751169	178	6	28	M14x2	56	0.50	4,500–8,500	9,000
RBG 17806/22,2 PIPE CT ST 0,50 72Z	751190	178	6	28	22.2	72	0.50	4,500–8,500	9,000
RBG 17806/M14 PIPE CT ST 0,50 72Z	751206	178	6	28	M14x2	72	0.50	4,500–8,500	9,000

Brushes with other threads are available on request.



IP packaging

Robust industrial packaging.



For tools specially suited to pipeline construction, see the brochure "PFERD tools for pipeline construction".



For detailed information and ordering data on PFERD reinforced grinding wheels for pipeline construction, please refer to Catalogue 206.



PFERDVIDEO

You will receive more information here or at www.pferd.com



An aggressive and robust brush that is able to withstand high mechanical loads. Suitable for all heavy stationary and automated brushing, e.g. deburring.

Recommendations for use:

- Suitable for use on stationary machines and bench grinders

Ordering example:

EAN 40072209**56557**

RBG 20016/50.8 ST 0.50

Please complete the description with the desired filament diameter.

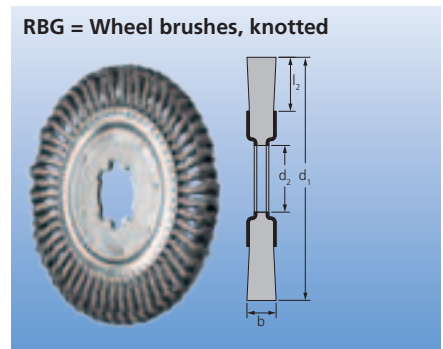

Description	Filament dia. d_f [mm]		Brush dia. d_1 [mm]	Face width b [mm]	Trim length l_2 [mm]	Arbor hole dia. d_2 [mm]	No. of knots	Rec. speed [RPM]	Max. perm. speed [RPM]	
	0.35	0.50								
	EAN 4007220									
Steel wire (ST)										
RBG 20016/50,8 ST	956540	956557	200	16	44	50.8	34	4,000–6,500	8,500	1
RBG 25016/50,8 ST	956564	956571	250	16	41	50.8	54	2,000–3,400	4,500	1



Adapter pairs APM 50.8
 Reduce the arbor hole diameters to the required dimensions. Suitable for the use of knotted wheel brushes on all standard tool drives.

For more information:
 For detailed information and ordering data on matching adapter sets and arbors, please refer to pages 44–46.

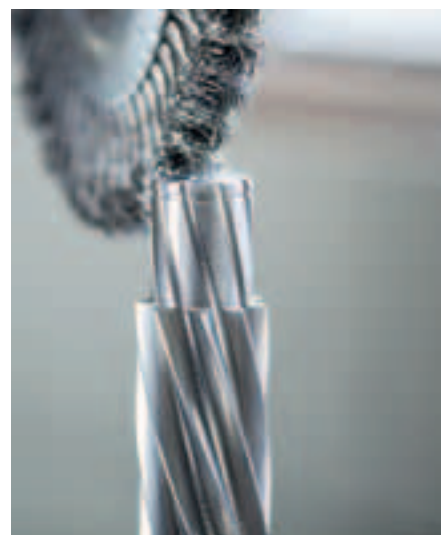

Stationary brushes

Wheel brushes, crimped

RBU = Wheel brushes, crimped, deburring brushes

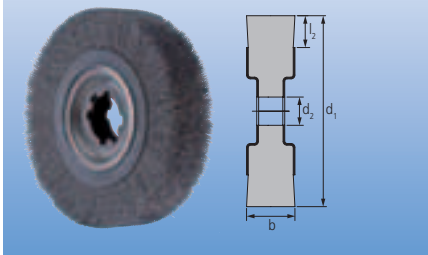

Particularly suitable for deburring pipes, cut edges and small parts on stationary machines. The special wire construction with cord wire filament (LIT) is particularly suitable for heavy brushing work and aggressive brushing.

Recommendations for use:

- Suitable for use on all common stationary deburring machines

Ordering example:

EAN 4007220807040

RBU 25060/50.8 ST 0.20

Please complete the description with the desired filament diameter.



Description	Filament dia. d_6 [mm]				Brush dia. d_1 [mm]	Face width b [mm]	Trim length l_2 [mm]	Arbor hole dia. d_2 [mm]	Max. arbor hole dia. d_2 [mm]	Rec. speed [RPM]	Max. perm. speed [RPM]	
	0.20	0.35	0.50	EAN 4007220								

Steel wire (ST)

LIT ST = stranded, brass-plated steel wire

RBU 25060/50,8 ST	807040	807057	807064	250	60	50	50.8	100.0	1,800–2,700	3,600	1
RBU 25060/50,8 LIT ST	-	807118	-	250	60	50	50.8	100.0	1,800–2,700	3,600	1
RBU 25080/50,8 ST	-	807071	807088	250	80	50	50.8	100.0	1,800–2,700	3,600	1
RBU 25080/50,8 LIT ST	-	807125	-	250	80	50	50.8	100.0	1,800–2,700	3,600	1
RBU 250100/50,8 ST	-	807095	807101	250	100	50	50.8	100.0	1,800–2,700	3,600	1

Stainless steel wire (INOX)

LIT INOX = stranded INOX wire

RBU 25060/50,8 INOX	807132	807149	807156	250	60	50	50.8	100.0	1,400–2,300	3,600	1
RBU 25060/50,8 LIT INOX	-	807200	-	250	60	50	50.8	100.0	1,400–2,300	3,600	1
RBU 25080/50,8 INOX	-	807163	807170	250	80	50	50.8	100.0	1,400–2,300	3,600	1
RBU 25080/50,8 LIT INOX	-	807217	-	250	80	50	50.8	100.0	1,400–2,300	3,600	1
RBU 250100/50,8 INOX	-	807187	807194	250	100	50	50.8	100.0	1,400–2,300	3,600	1

RBU = Wheel brushes, crimped, deburring brushes

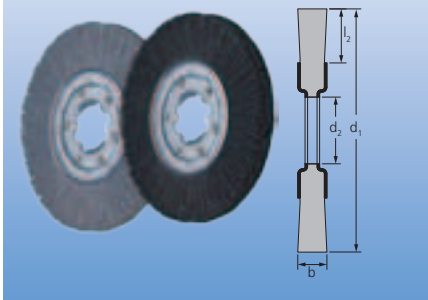

Its plastic filament makes this product particularly suitable for deburring complicated components such as cylinder heads or gear toothing. Ideal for processing aluminium due to the longer trim length and higher degree of flexibility.

Recommendations for use:

- Suitable for use on stationary machines, automated centres and robots
- Please see page 8 for information on selecting the correct abrasive grain



Description	Filament dia. d_6 [mm]				Brush dia. d_1 [mm]	Face width b [mm]	Trim length l_2 [mm]	Arbor hole dia. d_2 [mm]	Rec. speed [RPM]	Max. perm. speed [RPM]	
	120 0.55	120 1.10	180 0.90	320 0.55							

Plastic filament silicon carbide (SiC)

RBU 20013/50,8 SiC	807248	-	807255	807262	200	13	43	50.8	2,400–3,900	6,000	1
RBU 25015/50,8 SiC	807279	-	807286	807293	250	15	55	50.8	1,400–2,300	3,600	1

Plastic filament ceramic grain (CO)

RBU 20013/50,8 CO	-	837290	-	-	200	13	46	50.8	2,400–3,900	6,000	1
RBU 25015/50,8 CO	-	837306	-	-	250	15	63	50.8	1,400–2,300	3,600	1



Adapter pairs APM 50.8

Reduce the arbor hole diameters to the required dimensions. Suitable for the

use of deburring-brush type wheel brushes on all standard tool drives.

For more information:

For detailed information and ordering data on matching adapter sets and arbors, please refer to pages 44–46.

Its plastic filament makes this product particularly suitable for deburring complicated components such as cylinder heads or gear toothing. Developed specially for industrial use.

Advantages:

- Long tool life and aggressive brush effect due to a very high filament density
- Extremely smooth operation due to even distribution of the filament material

Recommendations for use:

- Particularly suitable for use on stationary machines, automated centres and robots
- Please see page 8 for information on selecting the correct abrasive grain

Ordering example:

EAN 40072209**56588**
 RBUP 15025/50.8 REC SiC 80 1.14
 Please complete the description with the desired filament diameter.

PFERDERGONOMICS®:

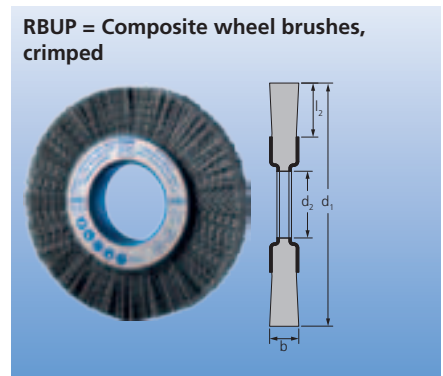

RBUP = Composite wheel brushes, crimped

Description	Filament dia. d_6 [mm]				Brush dia. d_1 [mm]	Face width b [mm]	Trim length l_2 [mm]	Arbor hole dia. d_2 [mm]	Rec. speed [RPM]	Max. perm. speed [RPM]	IP
	80 1.10	80 1.14	120 1.10	320 0.55							
EAN 4007220											

Plastic filament silicon carbide (SiC)

RBUP 15025/50,8 REC SiC	-	956588	-	-	150	25	32	50.8	900-1,500	3,600	1
RBUP 15025/50,8 SiC	956618	-	956649	956670	150	25	32	50.8	900-1,500	3,600	1
RBUP 20025/50,8 REC SiC	-	956595	-	-	200	25	32	50.8	900-1,500	3,600	1
RBUP 20025/50,8 SiC	956625	-	956656	956687	200	25	32	50.8	900-1,500	3,600	1
RBUP 25025/50,8 REC SiC	-	956601	-	-	200	25	38	50.8	900-1,500	3,600	1
RBUP 25025/50,8 SiC	956632	-	956663	956694	250	25	38	50.8	900-1,500	3,600	1

Plastic filament ceramic grain (CO)

RBUP 15025/50,8 CO	956700	-	-	-	150	25	32	50.8	900-1,500	3,600	1
RBUP 20025/50,8 CO	956717	-	-	-	200	25	32	50.8	900-1,500	3,600	1
RBUP 25025/50,8 CO	956724	-	-	-	250	25	38	50.8	900-1,500	3,600	1



IP packaging
Robust industrial packaging.



Adapter pairs AM 51
Reduce the arbor hole diameters to the required dimensions. Suitable for the use of composite wheel brushes on all standard tool drives.

For more information:

For detailed information and ordering data on matching adapter sets and arbors, please refer to pages 44-46.



Stationary brushes

Composite disc brushes, crimped

DBU = Composite disc brushes, crimped

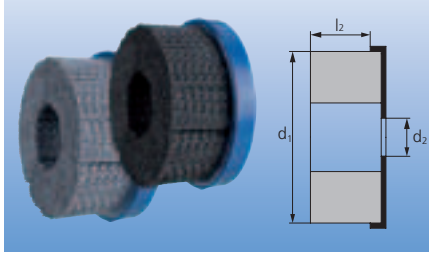

Particularly suitable for deburring and surface machining on stationary machines.

Advantages:

- Long tool life and aggressive brushing action due to a very high filament density
- Extremely smooth operation due to even distribution of the filament material

Recommendations for use:

- Suitable for stationary use on CNC machines, automated centres and robots
- Brushes with a diameter of 75 mm are supplied with an M14 thread and bridle and are therefore suitable for use with speed-adjustable angle grinders. The bridle

prevents the filaments from spreading out and increases the aggressive action of the brush. The bridle can be removed once the filaments are worn down. Then the rest of the filament can be used.

- Please see page 8 for information on selecting the correct abrasive grain
- All composite disc brushes with 22.2 mm diameter arbor hole are supplied with two drive pin holes with 6.5 mm diameter. Pitch circle diameter 31 mm.

PFERDERGONOMICS®:



Description	Packaging	Brush dia. d_1 [mm]	Trim length l_2 [mm]	Arbor hole dia./thread d_2 [mm]	Filament dia. d_6 [mm]	Rec. speed [RPM]	Max. perm. speed [RPM]
	 EAN 4007220						

Plastic filament silicon carbide (SiC)

DBUR 75/M14 REC SiC 80 1,14	899373	75	25	M14x2	1.14 x 2.30	2,400–3,900	6,000
DBUR 75/M14 SiC 80 1,10	899380	75	25	M14x2	1.10	2,400–3,900	6,000
DBU 100/22,2 REC SiC 80 1,14	808740	100	38	22.2	1.14 x 2.30	1,400–2,300	3,500
DBU 100/22,2 SiC 80 1,10	808757	100	38	22.2	1.10	1,400–2,300	3,500
DBU 100/22,2 SiC 120 1,10	808764	100	38	22.2	1.10	1,400–2,300	3,500
DBU 100/22,2 SiC 320 0,55	808771	100	38	22.2	0.55	1,400–2,300	3,500
DBU 125/22,2 REC SiC 80 1,14	808795	125	38	22.2	1.14 x 2.30	1,200–2,000	3,000
DBU 125/22,2 SiC 80 1,10	808788	125	38	22.2	1.10	1,200–2,000	3,000
DBU 125/22,2 SiC 120 1,10	808801	125	38	22.2	1.10	1,200–2,000	3,000
DBU 125/22,2 SiC 320 0,55	808818	125	38	22.2	0.55	1,200–2,000	3,000
DBU 150/22,2 REC SiC 80 1,14	808825	150	38	22.2	1.14 x 2.30	1,000–1,600	2,500
DBU 150/22,2 SiC 80 1,10	808849	150	38	22.2	1.10	1,000–1,600	2,500
DBU 150/22,2 SiC 120 1,10	808856	150	38	22.2	1.10	1,000–1,600	2,500
DBU 150/22,2 SiC 320 0,55	808863	150	38	22.2	0.55	1,000–1,600	2,500

Plastic filament ceramic grain (CO)

DBU 100/22,2 CO 120 1,10	837221	100	38	22.2	1.10	1,400–2,300	3,500
DBU 125/22,2 CO 120 1,10	837245	125	38	22.2	1.10	1,200–2,000	3,000
DBU 150/22,2 CO 120 1,10	837252	150	38	22.2	1.10	1,000–1,600	2,500



Arbor BO 12/22.2 6-13 (EAN 4007220808887)

For all composite disc brushes with diameter 100 mm.



Arbor BO 12/22.2 6-16 (EAN 4007220808894)

For all composite disc brushes with diameters 125 and 150 mm

For more information:

For detailed information

and ordering data on matching adapter sets and arbors, please refer to pages 44–46.



More PFERD tools and a large number of recommendations for use when working with aluminium can be found in our PRAXIS brochure "PFERD tools for use on aluminium". Please contact us.



Ideal for surface structuring of workpieces with large surfaces.

PFERD offers three different filament materials to suit different requirements:

■ **Steel wire (cord wire)**

Suitable for heavy-duty brushing work and aggressive brushing due to the special wire construction.

■ **Stainless steel wire (INOX)**

Suitable for structuring stainless steel (INOX) workpieces.

■ **Plastic filament (SiC)**

Suitable for structuring steel, stainless steel (INOX) and wood. Also suitable for fine deburring of holes and cut-outs on workpieces with large surfaces.

Recommendations for use:

■ Suitable for use on burnishing machines.

Ordering example:

EAN 4007220**773086**

WBU 100100/19.1 LIT ST 0.27

WBU = Wheel brushes, crimped

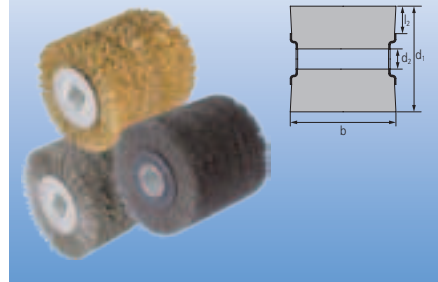

Description	Packaging	Brush dia. d ₁ [mm]	Face width b [mm]	Trim length l ₂ [mm]	Arbor hole dia. d ₂ [mm]	Filament dia. d ₆ [mm]	Rec. speed [RPM]	Max. perm. speed [RPM]
	 EAN 4007220							

Steel wire (LIT, ST)

Arbor hole with four keyways. LIT ST = stranded, brass-plated steel wire

WBU 100100/19,1 LIT ST 0,27	773086	100	100	26	19.1	0.27	3,000–4,500	6,000
-----------------------------	--------	-----	-----	----	------	------	-------------	-------

Stainless steel wire (INOX)

Arbor hole with four keyways.

WBU 100100/19,1 INOX 0,20	773079	100	100	26	19.1	0.20	2,400–3,900	6,000
---------------------------	--------	-----	-----	----	------	------	-------------	-------

Plastic filament silicon carbide (SiC)

Arbor hole with four keyways.

WBU 100100/19,1 SiC 80 1,27	773062	100	100	26	19.1	1.27	2,400–3,900	6,000
-----------------------------	--------	-----	-----	----	------	------	-------------	-------



IP packaging
Robust industrial packaging.

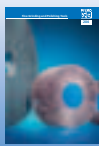

For detailed information and ordering data on other drum tools and drum sets, please refer to Catalogue 204.



For detailed information and ordering data on matching drum grinders, please refer to Catalogue 209.



Shank mounted end brushes

Shank mounted end brushes, crimped

PBU = End brushes, crimped

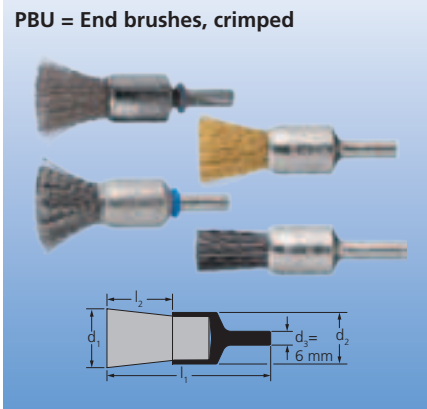

Suitable for light brushing such as deburring, cleaning and rust removal. Can be used particularly well in hard-to-reach areas, holes and cavities as the filaments spread out during rotation.

Recommendations for use:

- Recommended drive output minimum 300 watts



Ordering example:

EAN 4007220**530894**

PBU 1515/6 ST 0.20

For POS type, please add "POS" to the description.



Description	Packaging		Brush dia. d ₁ [mm]	Cup dia. d ₂ [mm]	Trim length l ₂ [mm]	Filament dia. d ₆ [mm]	Overall length l ₁ [mm]	Rec. speed [RPM]	Max. perm. speed [RPM]
									
	EAN 4007220								

Steel wire (ST)

PBU 1010/6 ST 0,20	-	530887	10	10	20	0.20	65	10,000–15,000	20,000
PBU 1010/6 ST 0,35	-	153277	10	10	20	0.35	65	10,000–15,000	20,000
PBU 1212/6 ST 0,20	-	562574	13	12	20	0.20	65	10,000–15,000	20,000
PBU 1212/6 ST 0,35	-	562581	13	12	20	0.35	65	10,000–15,000	20,000
PBU 1516/6 ST 0,20	894491	530894	15	16	22	0.20	65	9,000–13,500	18,000
PBU 1516/6 ST 0,35	532256	153253	15	16	22	0.35	65	9,000–13,500	18,000
PBU 2020/6 ST 0,20	894514	530900	20	22	25	0.20	70	9,000–13,500	18,000
PBU 2020/6 ST 0,50	532263	153222	20	22	25	0.50	70	9,000–13,500	18,000
PBU 3029/6 ST 0,20	-	530917	30	29	25	0.20	70	7,500–11,300	15,000
PBU 3029/6 ST 0,50	-	153192	30	29	25	0.50	70	7,500–11,300	15,000

Stainless steel wire (INOX)

Supplied with plastic-covered brush body. All INOX brushes are degreased.

PBU 1010/6 INOX 0,15	-	598023	10	10	20	0.15	65	8,000–13,000	20,000
PBU 1010/6 INOX 0,20	-	530924	10	10	20	0.20	65	8,000–13,000	20,000
PBU 1010/6 INOX 0,35	-	153291	10	10	20	0.35	65	8,000–13,000	20,000
PBU 1212/6 INOX 0,15	-	598030	13	12	20	0.15	65	8,000–13,000	20,000
PBU 1212/6 INOX 0,20	-	562598	13	12	20	0.20	65	8,000–13,000	20,000
PBU 1212/6 INOX 0,35	-	562604	13	12	20	0.35	65	8,000–13,000	20,000
PBU 1516/6 INOX 0,15	-	598047	15	16	22	0.15	65	7,200–11,700	18,000
PBU 1516/6 INOX 0,20	894545	530931	15	16	22	0.20	65	7,200–11,700	18,000
PBU 1516/6 INOX 0,35	532287	153260	15	16	22	0.35	65	7,200–11,700	18,000
PBU 2020/6 INOX 0,15	-	598054	20	22	25	0.15	70	7,200–11,700	18,000
PBU 2020/6 INOX 0,20	894552	530948	20	22	25	0.20	70	7,200–11,700	18,000
PBU 2020/6 INOX 0,50	532294	153246	20	22	25	0.50	70	7,200–11,700	18,000
PBU 3029/6 INOX 0,15	-	598061	30	29	25	0.15	70	6,000–9,800	15,000
PBU 3029/6 INOX 0,20	-	530955	30	29	25	0.20	70	6,000–9,800	15,000
PBU 3029/6 INOX 0,50	-	153215	30	29	25	0.50	70	6,000–9,800	15,000

Brass wire (MES)

PBU 1010/6 MES 0,30	-	153284	10	10	20	0.30	65	8,000–13,000	20,000
PBU 1212/6 MES 0,30	-	562611	13	12	20	0.30	65	8,000–13,000	20,000
PBU 1516/6 MES 0,30	-	220672	15	16	22	0.30	65	7,200–11,700	18,000
PBU 2020/6 MES 0,50	-	153239	20	22	25	0.50	70	7,200–11,700	18,000
PBU 3029/6 MES 0,50	-	153208	30	29	25	0.50	70	6,000–9,800	15,000

Plastic filament silicon carbide (SiC)

PBU 1010/6 SiC 180 0,90	-	220696	10	10	20	0.90	65	8,000–13,000	20,000
PBU 1212/6 SiC 180 0,90	-	562628	13	12	20	0.90	65	8,000–13,000	20,000
PBU 1516/6 SiC 180 0,90	532348	220689	15	16	22	0.90	65	7,200–11,700	18,000
PBU 2020/6 SiC 180 0,90	532355	220665	20	22	25	0.90	70	7,200–11,700	18,000
PBU 3029/6 SiC 180 0,90	-	220658	30	29	25	0.90	70	6,000–9,800	15,000



For particular applications, PFERD offers brushes in two special designs:

- **PBUL**
Extra long type for use in hard-to-reach areas.
- **PBUS**
Pointed conical shape for highly focused brushing in hard-to-reach areas.

Recommendations for use:

- Recommended drive output minimum 300 watts

Ordering example:

EAN 4007220659199

PBUL 1010/6 ST 0.20

Please complete the description with the desired filament diameter.

PBUL = End brushes, crimped, long type
PBUS = End brushes, crimped, pointed type

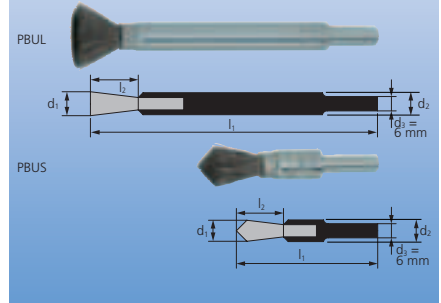

Description	Filament dia. d_6 [mm]		Brush dia. d_1 [mm]	Cup dia. d_2 [mm]	Trim length l_2 [mm]	Overall length l_1 [mm]	Rec. speed [RPM]	Max. perm. speed [RPM]	IP 	
	0.20	0.30								
	EAN 4007220									
Steel wire (ST)										
PBUL 1010/6 ST	659199	659205	10	10	20	120	4,000–9,500	20,000	10	
PBUS 1010/6 ST	-	659243	10	10	20	60	10,000–15,000	20,000	10	
Stainless steel wire (INOX)										
Supplied with plastic-covered brush body. All INOX brushes are degreased.										
PBUL 1010/6 INOX	659212	659229	10	10	20	120	3,500–9,000	20,000	10	
PBUS 1010/6 INOX	-	659250	10	10	20	60	8,000–13,000	20,000	10	

Shank mounted end brushes, encapsulated



Suitable for medium-heavy brushing. The steel wire is encapsulated in plastic for excellent tip control. Particularly suitable for recesses and holes.

Recommendations for use:

- Use brushes face down to intensify the brushing effect
- Recommended drive output minimum 300 watts

Ordering example:

EAN 4007220153321

PBV 2222/6 ST 0.25

PBV = End brushes, encapsulated

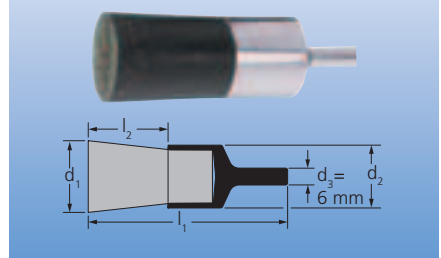

Description	Packaging	Brush dia. d_1 [mm]	Cup dia. d_2 [mm]	Trim length l_2 [mm]	Filament dia. d_6 [mm]	Overall length l_1 [mm]	Rec. speed [RPM]	Max. perm. speed [RPM]	
	 EAN 4007220								
Steel wire (ST)									
PBV 2222/6 ST 0,25	153321	22	22	25	0.25	70	6,500–9,800	13,000	
PBV 3030/6 ST 0,35	531112	30	29	25	0.35	70	6,500–9,800	13,000	



POS packaging

Individual promotional packaging for the PFERD TOOL-CENTER. For the entire range of brushes in POS packaging, please refer to pages 47–48.



IP packaging

Robust industrial packaging.

Shank mounted end brushes

Shank mounted end brushes, crimped, bridled

PBUR = End brushes, crimped, with removable bridles

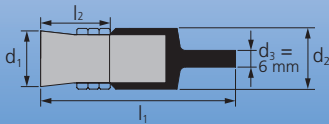

Suitable for light brushing such as deburring, cleaning and rust removal. Spreading out and flexibility of the brush filament can be strictly controlled thanks to the removable plastic bridles. Excellent for use in hard-to-reach areas, holes and cavities.

Recommendations for use:

- Recommended drive output minimum 300 watts

Ordering example:

EAN 4007220**530962**

PBUR 1212/6 ST 0.20

Please complete the description with the desired filament diameter.



Description	Filament dia. d_6 [mm]		Brush dia. d_1 [mm]	Cup dia. d_2 [mm]	Trim length l_2 [mm]	Overall length l_1 [mm]	Rec. speed [RPM]	Max. perm. speed [RPM]	
	0.20	0.35							
	EAN 4007220								

Steel wire (ST)

PBUR 1212/6 ST	530962	530979	13	16	25	70	7,500–11,300	15,000	10
PBUR 2020/6 ST	530986	530993	20	22	25	70	6,300–9,400	12,500	10
PBUR 2525/6 ST	531006	531013	25	30	25	70	6,300–9,400	12,500	10

Stainless steel wire (INOX)

Supplied with plastic-covered brush body. All INOX brushes are degreased.

PBUR 1212/6 INOX	531020	-	13	16	25	70	6,000–9,800	15,000	10
PBUR 2020/6 INOX	531037	-	20	22	25	70	5,000–8,100	12,500	10
PBUR 2525/6 INOX	531044	-	25	30	25	70	5,000–8,100	12,500	10

Shank mounted end brushes, knotted

PBGS = End brushes, knotted, SINGLETWIST® type

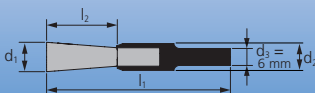

Particularly flexible single-knot brush for special applications. Excellent for processing inside corners as the brush is prevented from spreading out by the knot design that twists against the running direction of the brush.

Recommendations for use:

- Optimal results with speed-adjustable tool drives
- Recommended drive output minimum 500 watts



Description	Filament dia. d_6 [mm]			Brush dia. d_1 [mm]	Cup dia. d_2 [mm]	Trim length l_2 [mm]	Overall length l_1 [mm]	Rec. speed [RPM]	Max. perm. speed [RPM]	
	0.20	0.35	0.50							
	EAN 4007220									

Steel wire (ST) – SINGLETWIST® type

PBGS 1010/6 ST	659267	659274	659281	10	10	25	65	5,000–7,500	10,000	10
PBGS 1212/6 ST	807002	-	-	12	10	28	71	5,000–7,500	10,000	10

Stainless steel wire (INOX) – SINGLETWIST® type

Supplied with plastic-covered brush body. All INOX brushes are degreased.

PBGS 1010/6 INOX	659298	659304	659311	10	10	25	65	4,000–6,500	10,000	10
PBGS 1212/6 INOX	807019	-	-	12	10	28	71	4,000–6,500	10,000	10



PFERDVIDEO

You will receive more information here or at www.pferd.com



Aggressively working brush. Suitable for medium-duty brushing such as deburring, cleaning and rust removal. Can be used particularly well in hard-to-reach areas, holes and cavities as the wires spread out during rotation.

Recommendations for use:

- Use speed-adjustable tool drives to control the spread of the brush
- Recommended drive output minimum 500 watts

Ordering example:



EAN 4007220153314

PBG 1919/6 ST 0.35

For POS type, please add "POS" to the description.

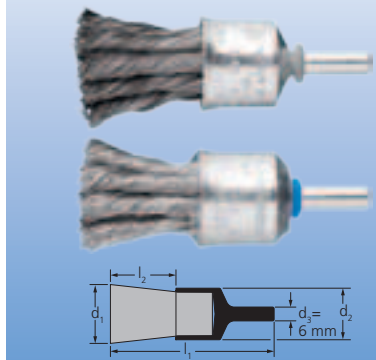
PBG = End brushes, knotted



Description	Packaging		Brush dia. d_1 [mm]	Cup dia. d_2 [mm]	Trim length l_2 [mm]	Filament dia. d_6 [mm]	Overall length l_1 [mm]	No. of knots	Rec. speed [RPM]	Max. perm. speed [RPM]
										
	EAN 4007220									
Steel wire (ST)										
PBG 1919/6 ST 0,25	-	936580	19	19	28	0.25	68	6	10,000–15,000	20,000
PBG 1919/6 ST 0,35	532416	153314	19	19	28	0.35	68	6	10,000–15,000	20,000
PBG 1919/6 ST 0,50	894361	531051	19	19	28	0.50	68	6	10,000–15,000	20,000
PBG 2323/6 ST 0,25	-	936603	23	23	28	0.25	68	8	10,000–15,000	20,000
PBG 2323/6 ST 0,35	-	936610	23	23	28	0.35	68	8	10,000–15,000	20,000
PBG 2323/6 ST 0,50	-	936627	23	23	28	0.50	68	8	10,000–15,000	20,000
PBG 3030/6 ST 0,25	-	936672	30	28	25	0.25	68	12	8,000–11,300	20,000
PBG 3030/6 ST 0,35	532423	531068	30	28	25	0.35	68	12	8,000–11,300	20,000
PBG 3030/6 ST 0,50	894422	531075	30	28	25	0.50	68	12	8,000–11,300	20,000

Stainless steel wire (INOX)

Supplied with plastic-covered brush body. All INOX brushes are degreased.

PBG 1919/6 INOX 0,15	-	598078	19	19	28	0.15	68	6	8,000–13,000	20,000
PBG 1919/6 INOX 0,25	-	936597	19	19	28	0.25	68	6	8,000–13,000	20,000
PBG 1919/6 INOX 0,35	532430	220702	19	19	28	0.35	68	6	8,000–13,000	20,000
PBG 1919/6 INOX 0,60	894460	531082	19	19	28	0.60	68	6	8,000–13,000	20,000
PBG 2323/6 INOX 0,15	-	936634	23	23	28	0.15	68	8	8,000–13,000	20,000
PBG 2323/6 INOX 0,25	-	936641	23	23	28	0.25	68	8	8,000–13,000	20,000
PBG 2323/6 INOX 0,35	-	936658	23	23	28	0.35	68	8	8,000–13,000	20,000
PBG 2323/6 INOX 0,60	-	936665	23	23	28	0.60	68	8	8,000–13,000	20,000
PBG 3030/6 INOX 0,15	-	598085	30	28	25	0.15	68	12	6,000–9,800	20,000
PBG 3030/6 INOX 0,25	-	936689	30	28	25	0.25	68	12	6,000–9,800	20,000
PBG 3030/6 INOX 0,35	532447	531099	30	28	25	0.35	68	12	6,000–9,800	20,000
PBG 3030/6 INOX 0,60	894484	531105	30	28	25	0.60	68	12	6,000–9,800	20,000



POS packaging

Individual promotional packaging for the PFERD TOOL-CENTER. For the entire range of brushes in POS packaging, please refer to pages 47–48.



IP packaging

Robust industrial packaging.



PFERDVIDEO

You will receive more information here or at www.pferd.com

Shank mounted wheel brushes

Shank mounted wheel brushes, crimped

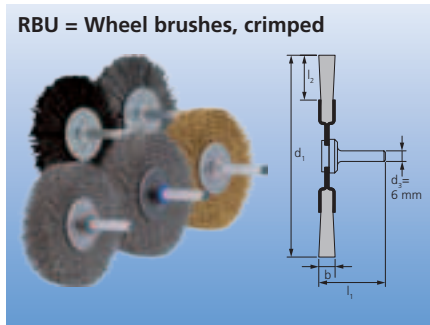

Suitable for universal cleaning, rust removal, smoothing, descaling, cleaning of cast seams, light deburring and removal of corrosion or paint.

Recommendations for use:

- Recommended drive output minimum 300 watts
- Please see page 8 for information on selecting the correct abrasive grain



Ordering example:

EAN 4007220153017



RBU 3006/6 ST 0.20

For POS type, please add "POS" to the description.



Description	Packaging		Brush dia. d ₁ [mm]	Face width b [mm]	Trim length l ₂ [mm]	Filament dia. d ₆ [mm]	Overall length l ₁ [mm]	Rec. speed [RPM]	Max. perm. speed [RPM]
									
EAN 4007220									
Steel wire (ST)									
RBU 2004/6 ST 0,20	-	152980	20	4	3	0.20	37	10,000–15,000	20,000
RBU 3006/6 ST 0,20	531808	153017	30	6	7	0.20	40	10,000–15,000	20,000
RBU 3009/6 ST 0,20	-	899250	30	9	7	0.20	42	10,000–15,000	20,000
RBU 4009/6 ST 0,20	-	153048	40	9	9	0.20	46	9,000–13,500	18,000
RBU 5004/6 ST 0,20	-	806593	50	4	9	0.20	41	7,500–11,300	15,000
RBU 5015/6 ST 0,20	531822	153079	50	15	13	0.20	50	7,500–11,300	15,000
RBU 6015/6 ST 0,20	-	658437	60	15	15	0.20	50	7,500–11,300	15,000
RBU 7004/6 ST 0,20	-	806609	70	4	9	0.20	41	7,500–11,300	15,000
RBU 7010/6 ST 0,30	-	658444	70	10	19	0.30	50	7,500–11,300	15,000
RBU 7015/6 ST 0,30	894606	153109	70	15	19	0.30	50	7,500–11,300	15,000
RBU 8004/6 ST 0,20	-	806616	80	4	10	0.20	41	6,000–9,000	12,000
RBU 8015/6 ST 0,30	-	153130	80	15	19	0.30	50	6,000–9,000	12,000
RBU 10010/6 ST 0,30	894613	658451	100	10	20	0.30	50	6,000–9,000	12,000
Stainless steel wire (INOX)									
RBU 2004/6 INOX 0,20	-	153000	20	4	3	0.20	37	8,000–13,000	20,000
RBU 3006/6 INOX 0,20	531884	153031	30	6	7	0.20	40	8,000–13,000	20,000
RBU 3009/6 INOX 0,20	-	899267	30	9	7	0.20	42	8,000–13,000	20,000
RBU 4009/6 INOX 0,20	-	153062	40	9	9	0.20	46	7,200–11,700	18,000
RBU 5004/6 INOX 0,20	-	806623	50	4	9	0.20	41	6,000–9,800	15,000
RBU 5015/6 INOX 0,20	531891	153093	50	15	13	0.20	50	6,000–9,800	15,000
RBU 6015/6 INOX 0,20	-	658468	60	15	15	0.20	50	6,000–9,800	15,000
RBU 7004/6 INOX 0,20	-	806630	70	4	9	0.20	41	6,000–9,800	15,000
RBU 7010/6 INOX 0,20	-	597835	70	10	19	0.20	50	6,000–9,800	15,000
RBU 7015/6 INOX 0,15	-	597842	70	15	19	0.15	50	6,000–9,800	15,000
RBU 7015/6 INOX 0,30	894620	153123	70	15	19	0.30	50	6,000–9,800	15,000
RBU 8004/6 INOX 0,20	-	806647	80	4	10	0.20	41	4,800–7,800	12,000
RBU 8010/6 INOX 0,20	-	578919	80	10	19	0.20	50	4,800–7,800	12,000
RBU 8015/6 INOX 0,15	-	597859	80	15	19	0.15	50	4,800–7,800	12,000
RBU 8015/6 INOX 0,30	-	153154	80	15	19	0.30	50	4,800–7,800	12,000
RBU 10010/6 INOX 0,30	894637	658475	100	10	20	0.30	50	4,800–7,800	12,000
Brass wire (MES)									
RBU 2004/6 MES 0,20	-	152997	20	4	3	0.20	37	8,000–13,000	20,000
RBU 3006/6 MES 0,20	-	153024	30	6	7	0.20	40	8,000–13,000	20,000
RBU 4009/6 MES 0,20	-	153055	40	9	9	0.20	46	7,200–11,700	18,000
RBU 5015/6 MES 0,20	-	153086	50	15	13	0.20	50	6,000–9,800	15,000
RBU 7015/6 MES 0,30	-	153116	70	15	19	0.30	50	6,000–9,800	15,000
RBU 8015/6 MES 0,30	-	153147	80	15	19	0.30	50	4,800–7,800	12,000
Plastic filament silicon carbide (SiC)									
RBU 5004/6 SiC 120 0,55	-	936511	50	4	13	0.55	50	6,000–9,800	15,000
RBU 5015/6 SiC 180 0,90	531945	220610	50	15	13	0.90	50	6,000–9,800	15,000

Continued on next page

Description	Packaging		Brush dia. d_1 [mm]	Face width b [mm]	Trim length l_2 [mm]	Filament dia. d_6 [mm]	Overall length l_1 [mm]	Rec. speed [RPM]	Max. perm. speed [RPM]
									
	EAN 4007220								
RBU 7008/6 SiC 120 0,55	-	936528	70	8	19	0.55	50	6,000–9,800	15,000
RBU 7015/6 SiC 180 0,90	894644	220627	70	15	19	0.90	50	6,000–9,800	15,000
RBU 8008/6 SiC 120 0,55	-	936535	80	8	19	0.55	50	4,800–7,800	12,000
RBU 8015/6 SiC 180 0,90	-	220634	80	15	19	0.90	50	4,800–7,800	12,000
Plastic filament ceramic grain (CO)									
RBU 5004/6 CO 120 0,55	-	936542	50	4	13	0.55	50	6,000–9,800	15,000
RBU 5015/6 CO 120 1,10	-	899342	50	15	13	1.10	50	6,000–9,800	15,000
RBU 7008/6 CO 120 0,55	-	936559	70	8	19	0.55	50	6,000–9,800	15,000
RBU 7015/6 CO 120 1,10	-	899359	70	15	19	1.10	50	6,000–9,800	15,000
RBU 8008/6 CO 120 0,55	-	936566	80	8	19	0.55	50	4,800–7,800	12,000
RBU 8015/6 CO 120 1,10	-	899366	80	15	19	1.10	50	4,800–7,800	12,000

Shank mounted wheel brushes, knotted



Aggressively working brush. For brushing in hard-to-reach grooves and recesses. Also suitable for cleaning, rust removal and processing of weld seams.

Recommendations for use:

- Recommended drive output minimum 500 watts

Ordering example:



EAN 4007220**153161**

RBG 7006/6 ST 0.35

For POS type, please add "POS" to the description.

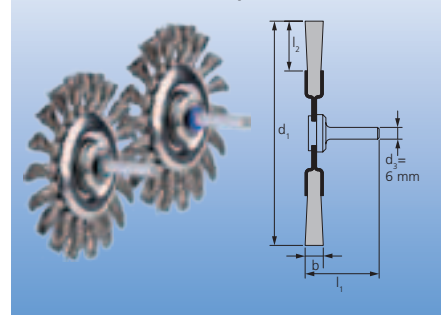
RBG = Wheel brushes, knotted



Description	Packaging		Brush dia. d_1 [mm]	Face width b [mm]	Trim length l_2 [mm]	Filament dia. d_6 [mm]	Overall length l_1 [mm]	No. of knots	Rec. speed [RPM]	Max. perm. speed [RPM]
										
	EAN 4007220									

Steel wire (ST)

RBG 7006/6 ST 0,35	531969	153161	76	6	16	0.35	42	18	12,500–18,800	25,000
RBG 7006/6 ST 0,50	894569	530177	76	6	16	0.50	42	18	12,500–18,800	25,000
RBG 7012/6 ST 0,35	-	658482	76	12	16	0.35	42	18	12,500–18,800	25,000
RBG 7012/6 ST 0,50	-	658680	76	12	16	0.50	42	18	12,500–18,800	25,000
RBG 10012/6 ST 0,35	-	530351	100	12	19	0.35	42	22	10,000–15,000	20,000
RBG 10012/6 ST 0,50	-	530399	100	12	19	0.50	42	22	10,000–15,000	20,000

Stainless steel wire (INOX)

All INOX brushes are degreased.

RBG 7006/6 INOX 0,35	531976	220641	76	6	16	0.35	42	18	10,000–16,300	25,000
RBG 7006/6 INOX 0,50	894576	530603	76	6	16	0.50	42	18	10,000–16,300	25,000
RBG 7012/6 INOX 0,35	-	658697	76	12	16	0.35	42	18	10,000–16,300	25,000
RBG 7012/6 INOX 0,50	-	659472	76	12	16	0.50	42	18	10,000–16,300	25,000
RBG 10012/6 INOX 0,35	-	530405	100	12	19	0.35	42	22	8,000–13,000	20,000
RBG 10012/6 INOX 0,50	-	530610	100	12	19	0.50	42	22	8,000–13,000	20,000



POS packaging

Individual promotional packaging for the PFERD TOOL-CENTER. For the entire range of brushes in POS packaging, please refer to pages 47–48.



IP packaging

Robust industrial packaging.

Shank mounted wheel brushes

Shank mounted wheel brushes, encapsulated

RBV = Wheel brushes, encapsulated

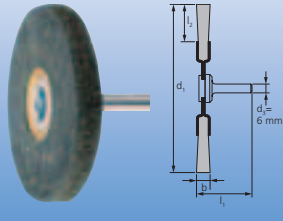

For medium-duty brushing. The wire is encapsulated in plastic for excellent tip control.

Recommendations for use:

- Recommended drive output minimum 300 watts

Ordering example:

EAN 4007220220955
RBV 6307/6 ST 0.30

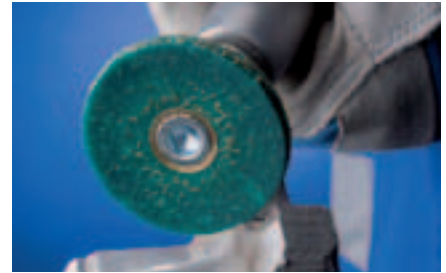

Description	Packaging	Brush dia. d ₁ [mm]	Face width b [mm]	Trim length l ₂ [mm]	Filament dia. d ₆ [mm]	Overall length l ₁ [mm]	Rec. speed [RPM]	Max. perm. speed [RPM]
	 EAN 4007220							

Steel wire (ST)

ST = brass-plated steel wire

RBV 6307/6 ST 0,30	220955	63	7	20	0.30	40	7,500–11,300	15,000
--------------------	--------	----	---	----	------	----	--------------	--------

Shank mounted bevel brushes

Shank mounted bevel brushes, crimped

KBU = Bevel brushes, crimped

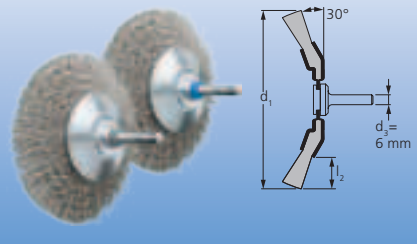

Excellent for medium-duty brushing such as deburring, cleaning and rust removal. Ideal for use in hard-to-reach areas such as inner edges, grooves and keyways due to bevelled shape of the brush.

Recommendations for use:

- Optimum results on speed-adjustable tool drives
- Suitable for use on straight grinders and flexible shaft drives

Ordering example:

EAN 4007220899397
KBU 9510/6 ST 0.30



Description	Packaging	Brush dia. d ₁ [mm]	Face width b [mm]	Trim length l ₂ [mm]	Filament dia. d ₆ [mm]	Rec. speed [RPM]	Max. perm. speed [RPM]
	 EAN 4007220						

Steel wire (ST)

KBU 5010/6 ST 0,20	936351	50	10	10	0.20	7,500–11,300	15,000
KBU 7010/6 ST 0,30	936368	70	10	15	0.30	7,500–11,300	15,000
KBU 8010/6 ST 0,30	936375	80	10	20	0.30	6,000–9,000	12,000
KBU 9510/6 ST 0,30	899397	95	10	25	0.30	6,000–9,000	12,000

Stainless steel wire (INOX)

All INOX brushes are degreased.

KBU 5010/6 INOX 0,20	936382	50	10	10	0.20	6,000–9,800	15,000
KBU 7010/6 INOX 0,15	936399	70	10	15	0.15	6,000–9,800	15,000
KBU 7010/6 INOX 0,20	936405	70	10	15	0.20	6,000–9,800	15,000
KBU 8010/6 INOX 0,30	936412	80	10	20	0.30	4,800–7,800	12,000
KBU 9510/6 INOX 0,30	899403	95	10	25	0.30	4,800–7,800	12,000



POS packaging

Individual promotional packaging for the PFERD TOOL-CENTER. For the entire range of brushes in POS packaging, please refer to pages 47–48.



IP packaging

Robust industrial packaging.



Universally suitable for cleaning, rust removal, smoothing, descaling and removal of corrosion or paint. Particularly suitable for use on large, flat and easily accessible surfaces due to face-down use with the entire brush face applied to the workpiece.

Recommendations for use:

- Recommended drive output minimum 300 watts

Ordering example:

EAN 4007220153345

TBU 5010/6 ST 0.30

For POS type, please add "POS" to the description.

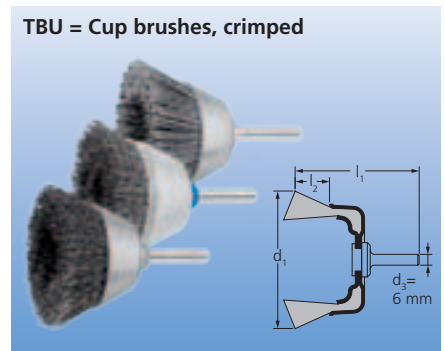

Description	Packaging		Brush dia. d ₁ [mm]	Face width b [mm]	Trim length l ₂ [mm]	Filament dia. d ₆ [mm]	Overall length l ₁ [mm]	Rec. speed [RPM]	Max. perm. speed [RPM]
	EAN 4007220								
Steel wire (ST)									
TBU 5010/6 ST 0,30	532171	153345	50	10	20	0.30	75	5,300–7,900	10,500
TBU 6015/6 ST 0,30	-	153352	60	15	20	0.30	85	2,200–3,400	4,500
Stainless steel wire (INOX)									
Supplied with plastic-covered brush body.									
TBU 5010/6 INOX 0,30	894651	579107	50	10	20	0.30	75	4,200–6,800	10,500
TBU 6015/6 INOX 0,30	-	579114	60	15	20	0.30	85	1,800–2,900	4,500
Plastic filament silicon carbide (SiC)									
TBU 5010/6 SiC 180 0,90	894668	220719	50	10	20	0.90	75	4,200–6,800	10,500
TBU 6015/6 SiC 180 0,90	-	220726	60	15	20	0.90	85	1,800–2,900	4,500

Brush sets

BSO 5500 ST

Contents: 80 pcs.

- 10 x RBU 3006/6 ST 0.20
- 10 x RBU 4009/6 ST 0.20
- 10 x RBU 5015/6 ST 0.20
- 10 x RBU 7015/6 ST 0.30
- 10 x TBU 5010/6 ST 0.30
- 10 x PBU 1010/6 ST 0.35
- 10 x PBU 1516/6 ST 0.35
- 10 x PBU 2020/6 ST 0.50

BSO 5600 ST

Contents: 23 pcs.

- 4 x TBU 5010/6 ST 0.30
- 10 x PBU 2020/6 ST 0.50
- 5 x RBU 5015/6 ST 0.20
- 4 x RBG 7006/6 ST 0.35

BSO 5600 INOX

Contents: 23 pcs.

- 4 x TBU 5010/6 INOX 0.30
- 10 x PBU 2020/6 INOX 0.50
- 5 x RBU 5015/6 INOX 0.20
- 4 x RBG 7006/6 INOX 0.35



Description	EAN 4007220	
BSO 5500 ST	220962	1
BSO 5600 ST	808368	1
BSO 5600 INOX	808375	1

Threaded cup brushes

Threaded cup brushes, crimped

TBU = Cup brushes, crimped

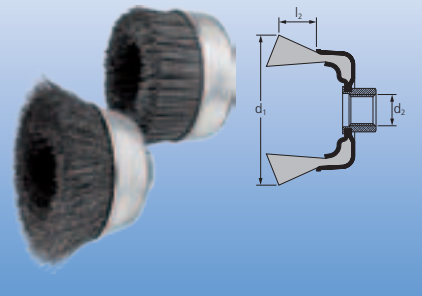

Excellent for medium-duty brushing on large surfaces, and for deburring, cleaning and rust removal.

Recommendations for use:

- Optimum results on speed-adjustable tool drives



Ordering example:

EAN 4007220**153543**

POS TBU 60/M14 ST 0,30

For the 5-piece packaging unit, please specify the description without "POS".



Description	Packaging		Brush dia. d_1 [mm]	Trim length l_2 [mm]	Thread d_2	Filament dia. d_6 [mm]	Rec. speed [RPM]	Max. perm. speed [RPM]
								
	EAN 4007220							
Steel wire (ST)								
POS TBU 60/M14 ST 0,30	153543	955192	60	20	M14x2	0.30	6,300–9,400	12,500
POS TBU 75/M14 ST 0,30	220849	955208	75	25	M14x2	0.30	6,300–9,400	12,500
POS TBU 100/M14 ST 0,30	153574	-	100	25	M14x2	0.30	4,300–6,400	8,500
Stainless steel wire (INOX)								
All INOX brushes are degreased.								
POS TBU 60/M14 INOX 0,30	721742	955215	60	20	M14x2	0.30	5,000–8,100	12,500
POS TBU 75/M14 INOX 0,30	220856	955222	75	25	M14x2	0.30	5,000–8,100	12,500
POS TBU 100/M14 INOX 0,30	220863	-	100	25	M14x2	0.30	3,400–5,500	8,500
Plastic filament silicon carbide (SiC)								
POS TBU 100/M14 SiC 120 1,00	530856	-	100	46	M14x2	1.00	2,400–3,900	6,000
POS TBU 100/M14 SiC 180 0,90	530870	-	100	46	M14x2	0.90	2,400–3,900	6,000

Brushes with other threads are available on request.



POS packaging

Individual promotional packaging for the PFERD TOOL-CENTER. For the entire range of brushes in POS packaging, please refer to pages 47–48.



IP packaging

Robust industrial packaging.





Aggressively working brush. Excellent for heavy-duty brushing on large surfaces, and for deburring, cleaning and rust removal.

Recommendations for use:

- Optimum results with high-performance angle grinders

Ordering example:

EAN 4007220153437
 POS TBG 65/M14 ST 0.35

For the 5-piece packaging unit, please specify the description without "POS".

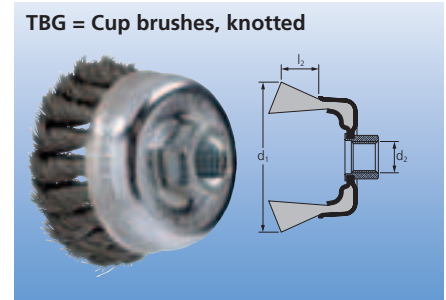

Description	Packaging		Brush dia. d ₁ [mm]	Trim length l ₂ [mm]	Thread d ₂	Filament dia. d ₆ [mm]	No. of knots	Rec. speed [RPM]	Max. perm. speed [RPM]
	EAN 4007220								

Steel wire (ST)

POS TBG 65/M14 ST 0,35	153437	955079	65	22	M14x2	0.35	18	6,300–12,500	12,500
POS TBG 65/M14 ST 0,50	579121	955086	65	22	M14x2	0.50	18	6,300–12,500	12,500
POS TBG 65/M14 ST 0,80	579138	-	65	22	M14x2	0.80	18	6,300–12,500	12,500
POS TBG 80/M14 ST 0,50	806654	955093	80	20	M14x2	0.50	20	5,000–10,000	10,000
POS TBG 100/M14 ST 0,50	806661	955109	100	25	M14x2	0.50	24	4,500–9,000	9,000

Stainless steel wire (INOX)

All INOX brushes are degreased.

POS TBG 65/M14 INOX 0,35	220740	955116	65	22	M14x2	0.35	18	5,000–12,500	12,500
POS TBG 65/M14 INOX 0,50	598016	955123	65	22	M14x2	0.50	18	5,000–12,500	12,500
POS TBG 80/M14 INOX 0,35	806678	955130	80	20	M14x2	0.35	20	4,000–10,000	10,000
POS TBG 100/M14 INOX 0,35	806685	955147	100	25	M14x2	0.35	24	3,600–9,000	9,000

Brushes with other threads are available on request.



PFERDVIDEO
 You will receive more information here or at www.pferd.com

Aggressively working brush. Excellent for heavy-duty brushing on large surfaces, and for deburring, cleaning and rust removal. The bridle prevents sideways spreading of the wires.

Recommendations for use:

- Optimum results with high-performance angle grinders
- Remove the bridle once the filament is worn down. Then the rest of the filament can be used.

Ordering example:

EAN 4007220153482
 TBGR 80/M14 ST 0.50

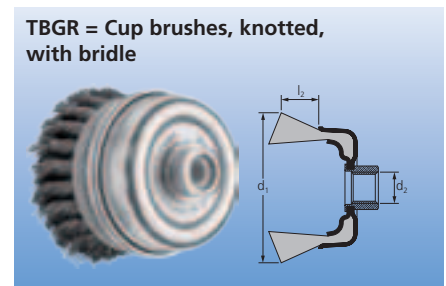

Description	Packaging		Brush dia. d ₁ [mm]	Trim length l ₂ [mm]	Thread d ₂	Filament dia. d ₆ [mm]	No. of knots	Rec. speed [RPM]	Max. perm. speed [RPM]
	EAN 4007220								

Steel wire (ST)

TBGR 80/M14 ST 0,50	153482		80	25	M14x2	0.50	22	4,300–8,500	8,500
TBGR 100/M14 ST 0,50	153505		100	25	M14x2	0.50	26	4,300–8,500	8,500
TBGR 100/5/8 ST 0,50	598009		100	25	5/8-11	0.50	26	4,300–8,500	8,500
TBGR 125/5/8 ST 0,50	584811		125	25	5/8-11	0.50	32	3,300–6,500	6,500
TBGR 150/5/8 ST 0,50	584828		150	20	5/8-11	0.50	40	2,800–5,500	5,500

Threaded cup brushes

Threaded cup brushes, knotted

TBG CT = Cup brushes, knotted, COMBITWIST® type

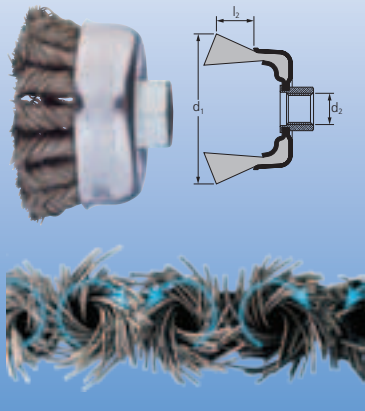

Aggressively working brush. Excellent for heavy-duty brushing on large surfaces. Also suitable for deburring, cleaning and rust removal.

Advantages:

- Smooth operation, even on corners and edges
- No recoiling of the brush when used on edges
- Enhanced tool life
- Increased stock removal rate
- Reduced likelihood of the knotting becoming "unravelling" in use

Recommendations for use:

- Optimum results with high-performance angle grinders

Ordering example:



EAN 4007220806692

POS TBG 65/M14 CT ST 0.35

For the 5-piece packaging unit, please specify the description without "POS".

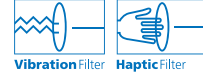
PFERDERGONOMICS®:



Description	Packaging		Brush dia. d ₁ [mm]	Trim length l ₁ [mm]	Thread d ₂	Filament dia. d ₆ [mm]	No. of knots	Rec. speed [RPM]	Max. perm. speed [RPM]
									
EAN 4007220									

Steel wire (INOX) – COMBITWIST® type

POS TBG 65/M14 CT ST 0,35	806692	955154	65	22	M14x2	0.35	18	6,300–12,500	12,500
POS TBG 65/M14 CT ST 0,50	806708	955161	65	22	M14x2	0.50	18	6,300–12,500	12,500
POS TBG 80/M14 CT ST 0,50	806715	955178	80	20	M14x2	0.50	20	5,000–10,000	10,000
POS TBG 100/M14 CT ST 0,50	806722	955185	100	25	M14x2	0.50	24	4,500–9,000	9,000

Stainless steel wire (INOX) – COMBITWIST® type

All INOX brushes are degreased.

POS TBG 65/M14 CT INOX 0,35	806739	-	65	22	M14x2	0.35	18	5,000–12,500	12,500
POS TBG 65/M14 CT INOX 0,50	806746	-	65	22	M14x2	0.50	18	5,000–12,500	12,500
POS TBG 80/M14 CT INOX 0,35	806753	-	80	20	M14x2	0.35	20	4,000–10,000	10,000
POS TBG 100/M14 CT INOX 0,35	806760	-	100	25	M14x2	0.35	24	3,600–9,000	9,000

Brushes with other threads are available on request.



POS packaging

Individual promotional packaging for the PFERD TOOL-CENTER. For the entire range of brushes in POS packaging, please refer to pages 47–48.



IP packaging

Robust industrial packaging.



PFERDVIDEO

You will receive more information here or at www.pferd.com





Excellent for medium-heavy brushing such as deburring, cleaning and rust removal. Ideal for use in hard-to-reach areas such as inner edges, grooves and keyways due to the bevelled shape of the brush.

Recommendations for use:

- Suitable for use on angle grinders up to 80 m/s
- Optimum results with speed-adjustable angle grinders

Ordering example:

EAN 4007220**220832**

POS KBU 10010/M14 ST 0.35

For the 5-piece packaging unit, please specify the description without "POS".

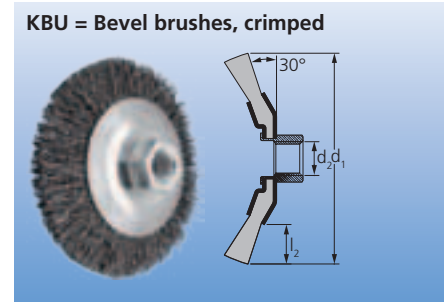

Description	Packaging		Brush dia. d ₁ [mm]	Face width b [mm]	Trim length l ₂ [mm]	Thread d ₂	Filament dia. d ₆ [mm]	Rec. speed [RPM]	Max. perm. speed [RPM]
	EAN 4007220								
Steel wire (ST)									
POS KBU 10010/M14 ST 0,35	220832	955314	100	10	22	M14x2	0.35	6,300–12,500	12,500
POS KBU 11510/M14 ST 0,35	806777	-	115	10	30	M14x2	0.35	6,300–12,500	12,500
Stainless steel wire (INOX)									
All INOX brushes are degreased.									
POS KBU 10010/M14 INOX 0,35	531129	955321	100	10	22	M14x2	0.35	5,000–12,500	12,500
POS KBU 11510/M14 INOX 0,35	806784	-	115	10	30	M14x2	0.35	5,000–12,500	12,500

Brushes with other threads are available on request.

Threaded bevel brushes, knotted



Aggressively working brush. Excellent for heavy-duty brushing such as deburring, cleaning and rust removal. Ideal for use in hard-to-reach areas such as inner edges, grooves and keyways due to the bevelled shape of the brush.

Recommendations for use:

- Optimum results with high-performance angle grinders

Ordering example:

EAN 4007220**153529**

POS KBG 10013/M14 ST 0.50

For the 5-piece packaging unit, please specify the description without "POS".

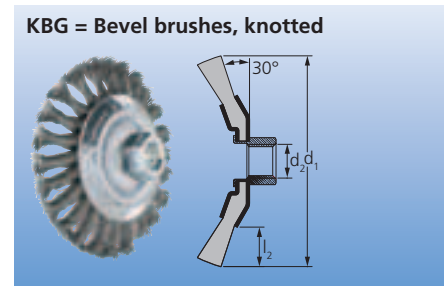

Description	Packaging		Brush dia. d ₁ [mm]	Face width b [mm]	Trim length l ₂ [mm]	Thread d ₂	Fila- ment dia. d ₆ [mm]	No. of knots	Rec. speed [RPM]	Max. perm. speed [RPM]
	EAN 4007220									
Steel wire (ST)										
POS KBG 10013/M14 ST 0,50	153529	955239	100	13	22	M14x2	0.50	22	10,000–15,000	20,000
POS KBG 11515/M14 ST 0,50	220818	955246	115	15	26	M14x2	0.50	22	7,500–12,500	15,000
POS KBG 12515/M14 ST 0,50	531167	-	125	15	19	M14x2	0.50	28	7,500–12,000	15,000
Stainless steel wire (INOX)										
All INOX brushes are degreased.										
POS KBG 10013/M14 INOX 0,35	220801	955253	100	13	22	M14x2	0.35	22	8,600–15,000	20,000
POS KBG 11515/M14 INOX 0,35	220825	955260	115	15	26	M14x2	0.35	22	6,000–12,500	15,000
POS KBG 12515/M14 INOX 0,35	531174	-	125	15	19	M14x2	0.35	28	6,000–12,000	15,000

Brushes with other threads are available on request.

Threaded bevel brushes

Threaded bevel brushes, knotted

KBG CT = Bevel brushes, knotted, COMBITWIST® type

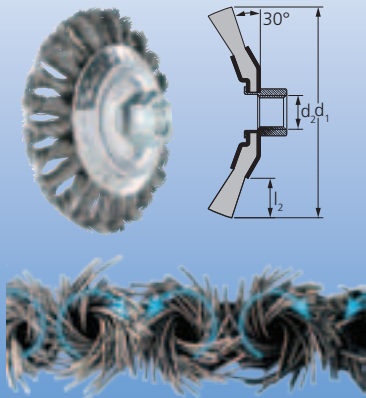

Aggressively working brush. Excellent for heavy-duty brushing such as deburring, cleaning and rust removal. Ideal for use in hard-to-reach areas such as inner edges, grooves and keyways due to the bevelled shape of the brush.

Advantages:

- Smooth operation, even on corners and edges
- No recoiling of the brush when used on edges
- Enhanced tool life
- Increased stock removal rate
- Reduced likelihood of the knotting becoming "unravalled" in use

Recommendations for use:

- Optimum results with high-performance angle grinders

Ordering example:



EAN 4007220593431

POS KBG 10013/M14 CT ST 0.50

For the 5-piece packaging unit, please specify the description without "POS".

PFERDERGONOMICS®:



Description	Packaging		Brush dia. d ₁ [mm]	Face width b [mm]	Trim length l ₂ [mm]	Thread d ₂	Fila-ment dia. d ₆ [mm]	No. of knots	Rec. speed [RPM]	Max. perm. speed [RPM]
										
	EAN 4007220									

Steel wire (INOX) – COMBITWIST® type

POS KBG 10013/M14 CT ST 0,50	593431	955277	100	13	22	M14x2	0.50	22	10,000–15,000	20,000
POS KBG 11515/M14 CT ST 0,50	593448	955284	115	15	26	M14x2	0.50	22	7,500–12,500	15,000
POS KBG 12515/M14 CT ST 0,50	593455	-	125	15	19	M14x2	0.50	28	7,500–12,000	15,000

Stainless steel wire (INOX) – COMBITWIST® type

All INOX brushes are degreased.

POS KBG 10013/M14 CT INOX 0,35	593462	955291	100	13	22	M14x2	0.35	22	8,000–15,000	20,000
POS KBG 11515/M14 CT INOX 0,35	593479	955307	115	15	26	M14x2	0.35	22	6,000–12,500	15,000
POS KBG 12515/M14 CT INOX 0,35	593486	-	125	15	19	M14x2	0.35	28	6,000–12,000	15,000

Brushes with other threads are available on request.



POS packaging

Individual promotional packaging for the PFERD TOOL-CENTER. For the entire range of brushes in POS packaging, please refer to pages 47–48.



IP packaging

Robust industrial packaging.



PFERDVIDEO

You will receive more information here or at www.pferd.com



PFERD INOX-TOTAL brushes

In addition to brushes with stainless steel (INOX) wire, PFERD also offers brushes in INOX-TOTAL design for machining stainless steel.

This version is characterised by the fact that not only the filament material, but also all parts of the brush are made of 1.4310 (V2A)-quality stainless steel (INOX). These brushes are perfectly suited for applications in extremely critical environments and for difficult application conditions in chemical and plant manufacturing and in the foodstuff industry or nuclear industry.

For more information about stainless steel (INOX) and PFERD INOX-TOTAL brushes, see page 9.

Structure of a wheel brush with arbor hole INOX-TOTAL

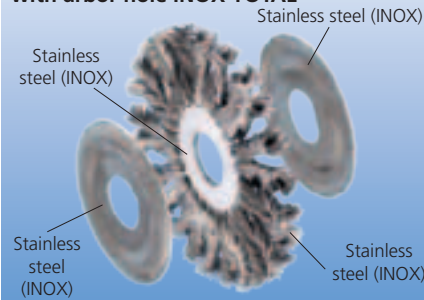

PFERDVIDEO

You will receive more information here or at www.pferd.com

Structure of an end brush INOX-TOTAL

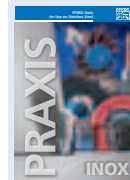
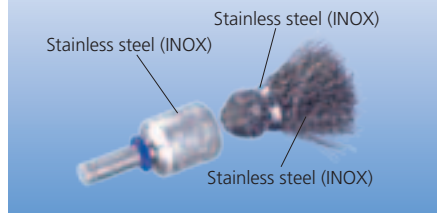

More PFERD tools and a large number of recommendations for use when working on stainless steel (INOX) can be found in our PRAXIS brochure "PFERD tools for use on stainless steel (INOX)". Please contact us.



Suitable for work in hard-to-reach places such as holes, cavities and inside corners.

PBUIIT

Suitable for all light brushing.

Can be used particularly well in hard-to-reach areas, holes and cavities as the wires spread out during rotation.

PBGSIT

Excellent for processing inside corners as the brush is prevented from spreading out by the knot design that twists against the running direction of the brush.

Ordering example:

EAN 4007220**808382**
PBUIIT 1516/6 INOX 0.15

PBUIIT = Shank mounted end brushes, crimped

PBGSIT = Shank mounted end brushes, knotted, SINGLETWIST® type

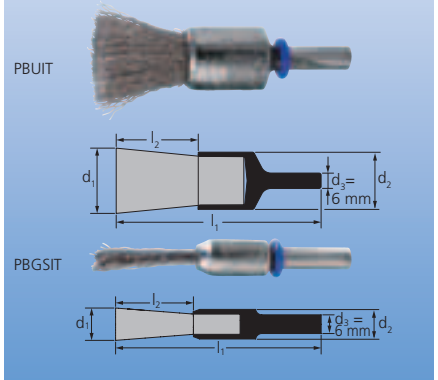

Description	Packaging	Brush dia. d_1 [mm]	Cup dia. d_2 [mm]	Trim length l_2 [mm]	Filament dia. d_6 [mm]	Overall length l_1 [mm]	Rec. speed [RPM]	Max. perm. speed [RPM]
	 EAN 4007220							

Stainless steel wire (INOX)

All INOX brushes are degreased, crimped

PBUIIT 1516/6 INOX 0,15	808382	15	16	22	0.15	65	7,200–11,700	18,000
PBUIIT 1516/6 INOX 0,20	808399	15	16	22	0.20	65	7,200–11,700	18,000
PBUIIT 2020/6 INOX 0,15	808405	20	22	25	0.15	70	7,200–11,700	18,000
PBUIIT 2020/6 INOX 0,20	808412	20	22	25	0.20	70	7,200–11,700	18,000
knotted – SINGLETWIST® knot style								
PBGSIT 1010/6 INOX 0,20	808429	10	10	25	0.20	65	4,000–6,500	10,000
PBGSIT 1010/6 INOX 0,35	808436	10	10	25	0.35	65	4,000–6,500	10,000

RBUIT = Shank mounted wheel brushes, crimped
RBGIT = Shank mounted wheel brushes, knotted

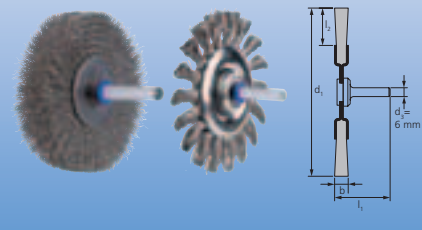

Universally suitable for cleaning, deburring and removal of heat discoloration.

The knotted wire design is particularly suitable for aggressive brushing.

Ordering example:
 EAN 4007220**808443**
 RBUIT 3006/6 INOX 0.20



Description	Packaging	Brush dia. d_1 [mm]	Face width b [mm]	Trim length l_2 [mm]	Filament dia. d_6 [mm]	No. of knots	Overall length l_1 [mm]	Rec. speed [RPM]	Max. perm. speed [RPM]
	 EAN 4007220								

Stainless steel wire (INOX)

All INOX brushes are degreased.
 crimped

RBUIT 3006/6 INOX 0,20	808443	30	6	7	0.20	-	40	8,000–13,000	20,000
RBUIT 5015/6 INOX 0,20	808450	50	15	13	0.20	-	50	6,000–9,800	15,000
RBUIT 7015/6 INOX 0,15	808467	70	15	19	0.15	-	50	6,000–9,800	15,000
RBUIT 7015/6 INOX 0,30	808474	70	15	19	0.30	-	50	6,000–9,800	15,000
RBUIT 8015/6 INOX 0,15	808481	80	15	19	0.15	-	50	4,800–7,800	12,000
RBUIT 8015/6 INOX 0,30	808498	80	15	19	0.30	-	50	4,800–7,800	12,000
knotted									
RBGIT 7006/6 INOX 0,35	808504	76	6	16	0.35	18	42	10,000–16,300	25,000

KBUIT = Shank mounted bevel brushes, crimped

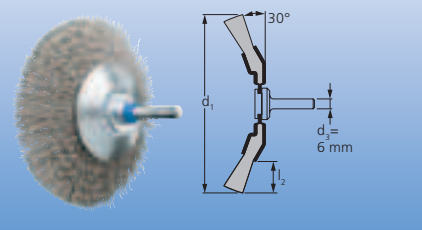

Excellent for medium-duty brushing such as deburring, cleaning and rust removal. Ideal for use in hard-to-reach areas such as inner edges, grooves and keyways due to the bevelled shape of the brush.

Recommendations for use:

- Suitable for use with straight grinders and flexible shaft drives
- Optimum results on speed-adjustable tool drives

Ordering example:
 EAN 4007220**936474**
 KBUIT 5010/6 INOX 0.20



Description	Packaging	Brush dia. d_1 [mm]	Face width b [mm]	Trim length l_2 [mm]	Filament dia. d_6 [mm]	Rec. speed [RPM]	Max. perm. speed [RPM]
	 EAN 4007220						

Stainless steel wire (INOX)

All INOX brushes are degreased.

KBUIT 5010/6 INOX 0,20	936474	50	10	10	0.20	6,000–9,800	15,000
KBUIT 7010/6 INOX 0,15	936481	70	10	15	0.15	6,000–9,800	15,000
KBUIT 7010/6 INOX 0,20	936498	70	10	15	0.20	6,000–9,800	15,000
KBUIT 8010/6 INOX 0,30	936504	80	10	20	0.30	4,800–7,800	12,000



IP packaging
 Robust industrial packaging.

RBGIT CT

Aggressively working brush. For heavy-duty brushing in metalwork such as descaling, rust removal, deburring, cleaning of weld seams and removal of adhesive residues.

RBGIT PIPE CT

Aggressive and robust brush that is able to withstand high mechanical loads. Perfect for heavy-duty brushing in pipeline and container construction. This extra slim brush design is ideal for work in hard-to-reach places e.g. root weld seams.

Advantages:

- Smooth operation, even on corners and edges
- No recoiling of the brush when used on edges
- Enhanced tool life
- Increased stock removal rate
- Reduced likelihood of the knotting becoming "unravelling" in use

Recommendations for use:

- Optimum results with high-performance speed-adjustable angle grinders

Ordering example:

EAN 4007220808511
POS RBGIT 11506/22.2 PIPE CT INOX 0.50

PFERDERGONOMICS®:



RBGIT = Wheel brushes, knotted
RBGIT PIPE = Wheel brushes, knotted, pipeline
CT = COMBITWIST® type

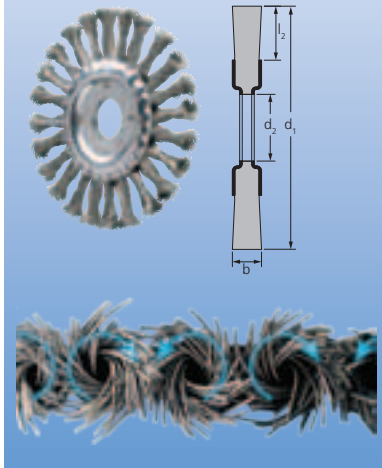

Description	Packaging	Brush dia. d ₁ [mm]	Face width b [mm]	Trim length l ₂ [mm]	Arbor hole dia. d ₂ [mm]	Fila-ment dia. d ₆ [mm]	No. of knots	Rec. speed [RPM]	Max. perm. speed [RPM]
									
	EAN 4007220								

Stainless steel wire (INOX) – COMBITWIST® type

All INOX brushes are degreased.

POS RBGIT 11512/22,2 CT INOX 0,35	808528	115	12	22	22.2	0.35	24	5,000–12,500	12,500
POS RBGIT 11506/22,2 PIPE CT INOX 0,50	808511	115	6	21	22.2	0.50	36	5,000–12,500	12,500



POS packaging

Individual promotional packaging for the PFERD TOOL-CENTER. For the entire range of brushes in POS packaging, please refer to pages 47–48.

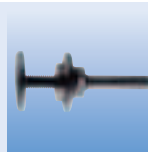

Arbor BO 8/22.2 5-10 (EAN 4007220751930)

For all knotted wheel brushes up to diameter 125 mm with arbor hole diameter 22.2 mm.

Safety note:

Arbors must only be used for brush diameters up to a maximum of 150 mm.

For more information:

For detailed information and ordering data on matching adapter sets and arbors, please refer to pages 44–46.



PFERDVIDEO

You will receive more information here or at www.pferd.com



Tube brushes

Tube brushes

IBU = Threaded tube brushes, crimped

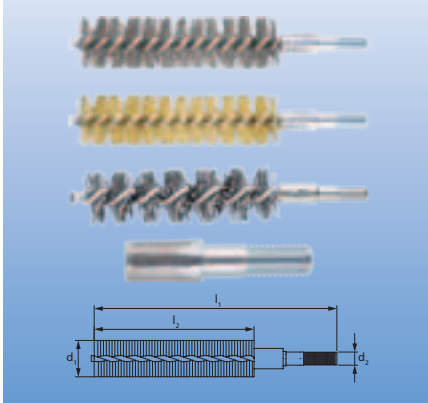

Particularly suitable for the deburring and cleaning of pipes, threads, coupling sleeves and cylinders. In addition to the thread, tube brushes up to 20 mm have a shank allowing them to be clamped into 6 mm collets. Tube brushes with 3/8 threads are also equipped with a shank of 10 mm.

Recommendations for use:

- Developed for use with low rotational speeds of up to 1,000 RPM

Ordering note:

Filament material diameter SiC tube brushes 1.00 mm

Ordering example:

EAN 4007220**659533**

IBU 0880/M6 ST 0.15

Please complete the description with the desired filament material and filament diameter.



Description	Filament material				Brush dia. d ₁ [mm]	Trim length l ₂ [mm]	Thread d ₂	Filament dia. d ₅ [mm]	Overall length l ₁ [mm]	IP
	Steel	INOX	Brass	SiC 180						
	EAN 4007220									
IBU 0880/M6	659533	659540	659557	659564	8	80	M6	0.15	120	10
IBU 1080/M6	659571	659588	659595	659601	10	80	M6	0.15	120	10
IBU 1280/M6	659618	659625	659632	659649	12	80	M6	0.15	120	10
IBU 1380/M6	660447	660454	660461	660478	13	80	M6	0.20	120	10
IBU 1580/M6	660485	660515	660522	660539	15	80	M6	0.20	120	10
IBU 1680/M6	660546	660553	660560	660577	16	80	M6	0.20	120	10
IBU 1880/M6	660584	660591	660607	660614	18	80	M6	0.20	120	10
IBU 2080/M6	660621	660638	660645	660652	20	80	M6	0.20	120	10
IBU 22100/3/8 BSW	660669	660676	660683	660690	22	100	3/8	0.20	170	10
IBU 25100/3/8 BSW	660706	660713	660720	660737	25	100	3/8	0.20	170	10
IBU 30100/3/8 BSW	660744	660751	660768	660775	30	100	3/8	0.20	170	10
IBU 32100/1/2 BSW	749425	749449	749456	-	32	100	1/2	0.25	170	10
IBU 38100/1/2 BSW	749463	749470	749487	-	38	100	1/2	0.30	170	10
IBU 40100/1/2 BSW	749494	749500	749517	-	40	100	1/2	0.30	170	10
IBU 44100/1/2 BSW	749524	749531	749548	-	44	100	1/2	0.30	170	10
IBU 50100/1/2 BSW	749555	-	-	-	50	100	1/2	0.35	170	5
IBU 57100/1/2 BSW	749562	-	-	-	57	100	1/2	0.35	170	5
IBU 63100/1/2 BSW	749579	-	-	-	63	100	1/2	0.35	170	5
IBU 69100/1/2 BSW	749586	-	-	-	69	100	1/2	0.35	170	5
IBU 75100/1/2 BSW	749593	-	-	-	75	100	1/2	0.35	170	1
IBU 82100/1/2 BSW	749609	-	-	-	82	100	1/2	0.35	170	1
IBU 101100/1/2 BSW	749616	-	-	-	101	100	1/2	0.50	170	1

SWG = Quick-change handles



Suitable for manual work with tube brushes. Quick-change handles can also be combined and supplemented with the IBUV extensions. Please refer to the table "Combination options" on page 41 for all possible length combinations.

The SWG-6 quick-change handle incorporates a collet in which tools with a shank diameter

of 6 mm can be clamped. All group 10 collets can be used. Please refer to Catalogue 209 for detailed information and ordering data.

Ordering example:

EAN 4007220**721803**

SWG-M6

Please complete the description with the desired thread.

Description	Thread				Overall length l ₁ [mm]	IP
	M6	3/8	1/2	Collet 6 mm		
	EAN 4007220					
SWG-	721803	723036	749333	-	135	1
SWG-6	-	-	-	723043	150	1

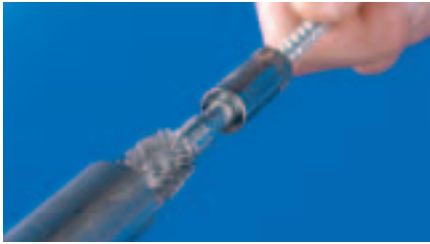

In order to work in hard-to-reach areas, tube brushes, extensions (IBUV), wire shanks (IBUS) or quick-change handles (SWG) are used.

Please refer to the table "Combination options" for all possible length combinations. Please note the outer diameter of the screw socket:

M6 = 12 mm
 3/8 = 12 mm
 1/2 = 16 mm

Ordering example:
 EAN 4007220726884
 IBUV M6 300

Please complete the description with the desired thread.

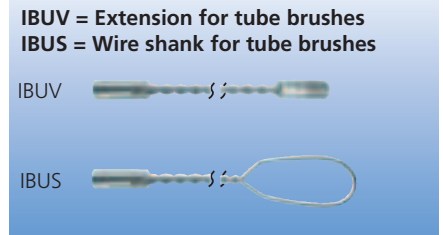

Description	Thread			Overall length l ₁ [mm]	IP
	M6	3/8	1/2		
	EAN 4007220				
IBUV ... 300	726884	726891	750032	300	1
IBUV ... 1000	660782	660799	750049	1,000	1
IBUS ... 300	726907	726914	750094	300	1
IBUS ... 1000	660805	660812	750100	1,000	1

Combination options

The extensions (IBUV) and wire shanks (IBUS) can be combined with one another in a number of different permutations in order to achieve the desired overall length. Extensions (IBUV) can be combined with one another.

Example:
 IBUV 1000 (extension) + IBUS 300 (wire shank)
 = Desired total length 1,300 mm

Extension	SWG [mm]	IBUS 300 [mm]	IBUS 1000 [mm]
without	135	300	1,000
IBUV 300	435	600	1,300
IBUV 1000	1,135	1,300	2,000



Especially suitable for brushing in hard-to-reach areas such as internal pipe surfaces and holes in manual applications.

Ordering note:
 Nylon filament without abrasive grain

Ordering example:
 EAN 4007220748923
 IBU 06100 ST 0.15
 Please complete the description with the desired filament material and filament diameter.

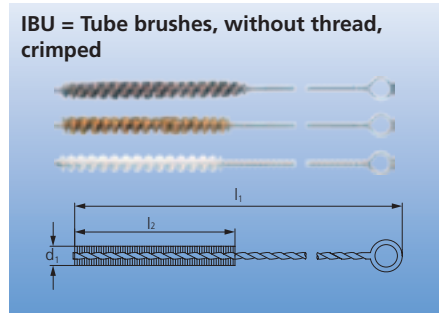

Description	Filament material					Brush dia. d ₁ [mm]	Trim length l ₂ [mm]	Overall length l ₁ [mm]	IP
	Steel 0.15	INOX 0.15	Brass 0.15	Nylon 0.20	Nylon 0.30				
	EAN 4007220								
IBU 06100	748923	748930	748947	748961	-	6	100	300	10
IBU 08100	748985	748992	749005	749012	-	8	100	300	10
IBU 10100	749036	749050	749043	749067	-	10	100	300	10
IBU 12100	749074	749081	749098	-	749104	12	100	300	10
IBU 15100	749111	749128	749142	-	749159	15	100	300	10
IBU 20100	749166	749173	749180	-	749197	20	100	300	10
IBU 25100	749203	749210	749227	-	749708	25	100	300	10
IBU 30100	749241	749258	749265	-	749272	30	100	300	10

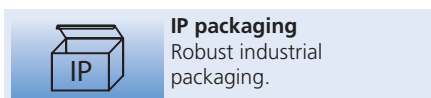

Scratch brushes

Scratch brushes

HBU = Scratch brushes for universal application

Can be used universally for all light cleaning work and rust removal.

HBU LH = Long Handle (LH) scratch brushes

Suitable for cleaning, rust removal, weld seam cleaning and cleaning of surfaces. Extra long handle.

HBUP = Scratch brushes with plastic bodies

Can be used universally for all light cleaning work and rust removal. The curved two-component handle allows safe and ergonomic work. The version with stainless steel (INOX) wire is approved for use in the foodstuff industry.



HBK = Scratch brushes for fillet welds

Suitable for the cleaning and derusting of fillet welds and V seams due to V-shape.

Ordering example:

EAN 4007220659489

HBU 10 ST 0.35

Please complete the description with the desired filament material and filament diameter.

HBU = Scratch brushes for universal application

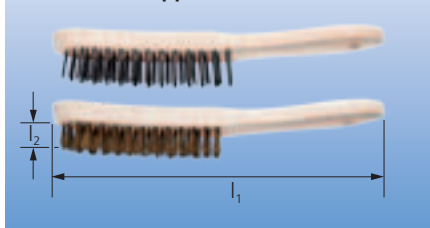

Description	Filament material			No. of rows Z	Trim length l_2 [mm]	Overall length l_1 [mm]	IP
	Steel 0.35	INOX 0.30	Brass 0.30				
	EAN 4007220						
HBU 10	659489	659496	-	1	25	290	10
HBU 20	572191	572221	572528	2	25	290	10
HBU 30	572207	572238	572535	3	25	290	10
HBU 40	572214	572245	572542	4	25	290	10
HBU 50	153741	572252	572559	5	25	290	10
HBU 60	713341	713365	-	6	25	290	10
Bulk pack							
HBU 30 GP	808320	-	-	3	25	290	50
HBU 40 GP	808337	808351	-	4	25	290	50
HBU 50 GP	808344	-	-	5	25	290	50

HBU LH = Scratch brushes Long Handle (LH)

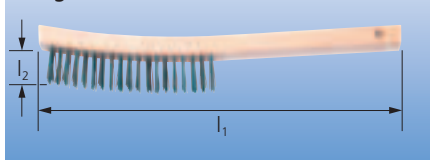

Description	Filament material	No. of rows Z	Trim length l_2 [mm]	Overall length l_1 [mm]	IP
	Steel 0.35				
	EAN 4007220				
HBH LH 30	616840	3	25	350	10
HBH LH 40	616857	4	25	350	10

HBUP = Scratch brushes with plastic bodies

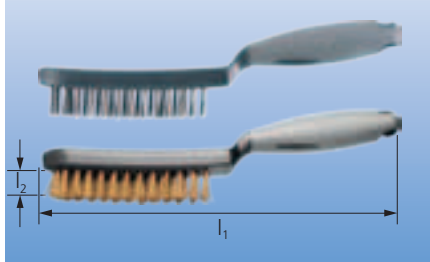

Description	Filament material			No. of rows Z	Trim length l_2 [mm]	Overall length l_1 [mm]	IP
	Steel 0.40	INOX 0.40	Brass 0.30				
	EAN 4007220						
HBUP 10	906583	906743	-	1	25	290	10
HBUP 20	906590	906750	906712	2	25	290	10
HBUP 30	906644	906767	906729	3	25	290	10
HBUP 40	906651	906774	906736	4	25	290	10
HBUP 50	906705	906781	-	5	25	290	10

HBK = Scratch brushes for fillet welds

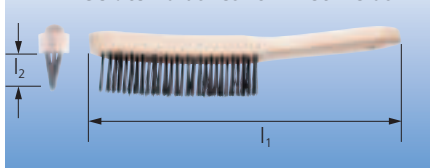

Description	Filament material		No. of rows Z	Trim length l_2 [mm]	Overall length l_1 [mm]	IP
	Steel 0.35	INOX 0.35				
	EAN 4007220					
HBK 30	572481	572498	3	35	290	10



IP packaging
Robust industrial packaging.

Note:

All scratch brushes are supplied with a hanging hole and are therefore perfect for presentation on the PFERD TOOL-CENTER. For easy identification, all scratch brushes are marked with EAN, description and filament material.

HBG = Scratch brushes, curved type

Ideally suited for cleaning work in hard-to-reach areas e.g. angles, corners and pipes.

Steel = brass-coated steel wire

HBZ = Scratch brushes for spark plugs

Ideally suited for cleaning spark plugs, small workpieces and tools.

HBB = Scratch brushes/block brushes

Ideally suited for cleaning and rust removal on surfaces.

HBF = Scratch brushes for files

Suited for cleaning files.

HBFM = Scratch brushes for precision mechanics

Ideally suited for light cleaning work on fine surfaces. The filament diameter of 0.15 mm

allows a smooth brushing action and produces a smooth surface.

Ordering example:

EAN 4007220**153727**

HBG 10 ST 0.30

Please complete the description with the desired filament material and filament diameter.

Description	Filament material			No. of rows Z	Trim length l_2 [mm]	Overall length l_1 [mm]	IP
	Steel 0.30	INOX 0.30	Brass 0.30				
	EAN 4007220						
HBG 10	153727	153734	572672	1	25	265	10

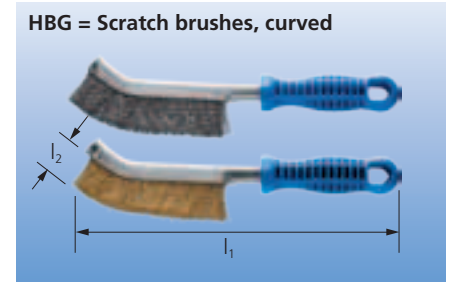

Description	Filament material	No. of rows Z	Trim length l_2 [mm]	Overall length l_1 [mm]	IP
	Brass 0.15				
	EAN 4007220				
HBZ 30	572566	3	15	145	10

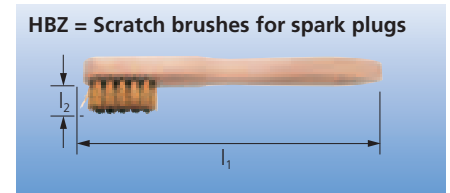

Description	Filament material		No. of rows Z	Trim length l_2 [mm]	Overall length l_1 [mm]	IP
	Steel 0.35	Brass 0.30				
	EAN 4007220					
HBB 50	572504	573020	5	35	200	10

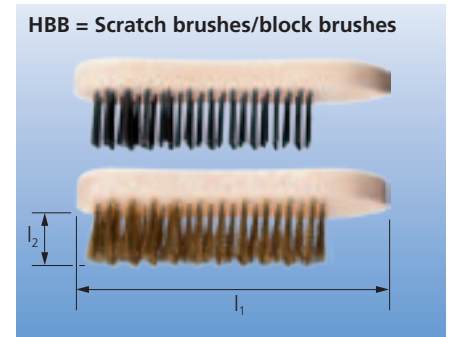

Description	Filament material	No. of rows Z	Trim length l_2 [mm]	Overall length l_1 [mm]	IP
	Steel 0.15				
	EAN 4007220				
HBF 10	015315	1	7	232	5

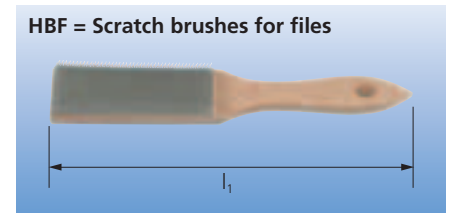

Description	Filament material			No. of rows Z	Trim length l_2 [mm]	Overall length l_1 [mm]	IP
	Steel 0.15	INOX 0.15	Brass 0.15				
	EAN 4007220						
HBFM 40	659502	659519	659526	4	20	220	10

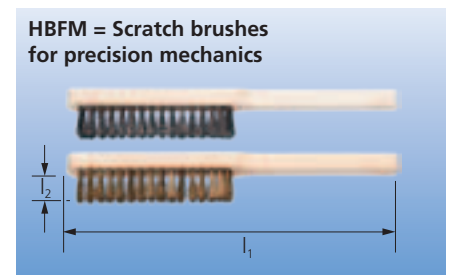

In order to be able to use knotted and crimped wheel brushes and disc brushes with arbor hole on tool drives with collet chuck, PFERD offers an arbor suitable for every brush type.

The arbor that is suitable for your brush type is listed in the table below.

Examples of brushes with arbors

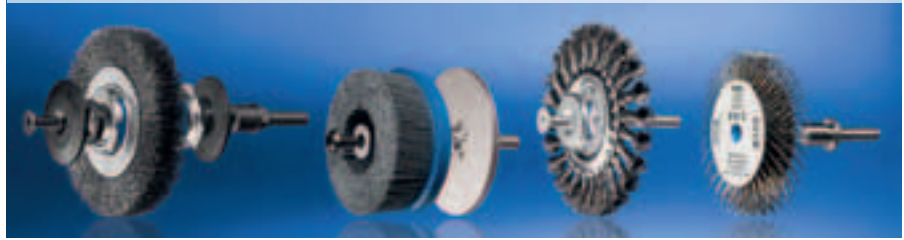

Arbors

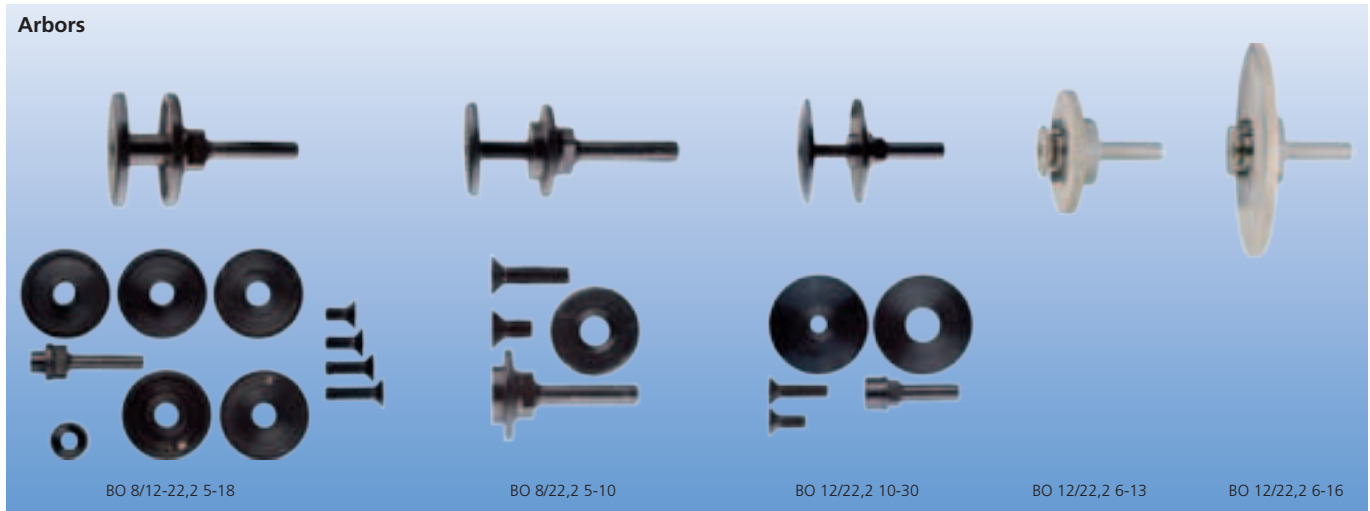

Enables use of wheel brushes with arbor hole on tool drives with collet, e.g. electric straight grinders and flexible shaft drives.

Please refer to Catalogue 209 for detailed information and ordering data for tool drives.

Safety notes:

- Arbors must only be used for brush diameters up to a maximum of 150 mm.

Description	EAN 4007220	Shank dia. [mm]	Clamping width [mm]	Suitable for	Page	IP
BO 8/12-22,2 5-18	751923	8	5-18	Wheel brushes crimped (RBU) up to dia. 150 mm, narrow face Wheel brushes crimped (RBU) 10020, wide face Wheel brushes crimped (RBU) 12520, wide face	11 12, 13 12, 13	1
BO 8/22,2 5-10	751930	8	5-10	Wheel brushes crimped (RBU) 10028, wide face Wheel brushes crimped (RBU) 12528, wide face Wheel brushes knotted (RBG) up to dia. 125 mm with 22.2 mm arbor hole	12, 13 12, 13 15, 16	1
BO 12/22,2 10-30	561317	12	10-30	Wheel brushes crimped (RBU) dia. 150 mm, wide face Wheel brushes knotted (RBG) dia. 150 mm	12, 13 15	1
BO 12/22,2 6-13	808887	12	6-13	Composite disc brushes (DBU) with dia. 100 mm	22	1
BO 12/22,2 6-16	808894	12	6-16	Composite disc brushes (DBU) with dia. 125 up to 150 mm	22	1

Arbor for POLISCRATCH brush BO 8/M14



Suitable for attaching POLISCRATCH brushes to straight grinders, flexible shafts or power drills.

Safety notes:

- Exclusively for use with POLISCRATCH brushes.

Description	EAN 4007220	Thread	Shank dia. [mm]	Suitable for	Page	IP
BO 8/M14	900482	M14	8	Wheel brushes crimped (RBU), POLISCRATCH type	14	1



IP packaging
Robust industrial packaging.

In order to reduce the arbor hole diameter to the required dimension, PFERD offers a matching adapter set for crimped wheel brushes with arbor hole of the types

- narrow face
- wide face
- deburring brush
- composite brush

The form-fit nature of the system prevents the movement of the brush while in use.

The arbor hole diameters contained in the set can be determined using the tables below.

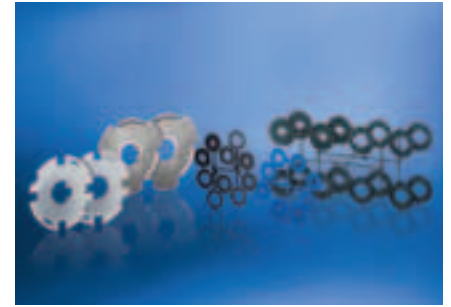



With adapter set AK 32, wheel brushes, narrow face, can be used on all common tool drives.

Recommendations for use:

- Particularly suitable for applications that produce little heat and require little pressure

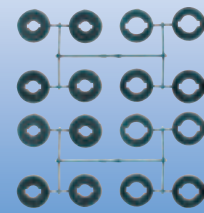
Adapter set AK 32



Description	EAN 4007220	Arbor hole dia. contained in the set [mm]	Suitable for	Page	
AS AK 32	608593	20.0 / 18.0 / 14.0 / 12.0 / 25.4 (1) / 22.2 (7/8) / 16.0 (5/8) / 12.7 (1/2)	RBU, narrow face ≥ dia. 150 mm	11	1





With adapter set AK 32-2, wheel brushes, wide face, can be used on all common tool drives.

Recommendations for use:

- Particularly suitable for applications that produce little heat and require little pressure
- For applications that produce a lot of heat and involve high pressure, please use adapter sets AM 51

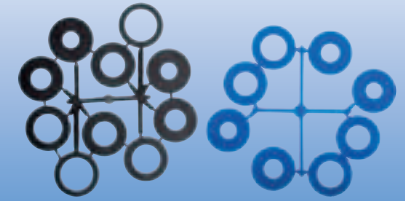
Adapter set AK 32-2



Description	EAN 4007220	Arbor hole dia. contained in the set [mm]	Suitable for	Page	
AS AK 32-2	806890	31.75 / 20.0 / 18.0 / 14.0 / 12.0 / 25.4 (1) / 22.2 (7/8) / 19.2 (.750) / 16.0 (5/8) / 12.7 (1/2)	RBU, wide face ≥ dia. 150 mm	12, 13	1

Adapter pairs AM 51



With adapter pairs AM 51, wheel brushes, wide face type, and composite wheel brushes with a diameter of 150 mm or more, can be used on all common tool drives. An adapter set consists of 2 individual adapters.

Recommendations for use:

- Particularly suitable for applications which produce a lot of heat and involve high pressure
- For applications that produce less heat and require low pressure, please use adapter set AK 32-2

Ordering example:

EAN 4007220**549803**

AP AM 51/14.0



Description	EAN 4007220	Arbor hole dia. contained in the set [mm]	Suitable for	Page	
AP AM 51/14,0	549803	14.0	RBU, wide face, ≥ dia. 150 mm RBUP with composite body, ≥ dia. 150 mm	12, 13 21	1
AP AM 51/16,0	548486	16.0	RBU, wide face, ≥ dia. 150 mm RBUP with composite body, ≥ dia. 150 mm	12, 13 21	1
AP AM 51/20,0	549834	20.0	RBU, wide face, ≥ dia. 150 mm RBUP with composite body, ≥ dia. 150 mm	12, 13 21	1
AP AM 51/22,2	806906	22.2	RBU, wide face, ≥ dia. 150 mm RBUP with composite body ≥ dia. 150 mm	12, 13 21	1
AP AM 51/25,4	548509	25.4	RBU, wide face, ≥ dia. 150 mm RBUP with composite body, ≥ dia. 150 mm	12, 13 21	1
AP AM 51/30,0	806913	30.0	RBU, wide face, ≥ dia. 150 mm RBUP with composite body, ≥ dia. 150 mm	12, 13 21	1
AP AM 51/32,0	606605	32.0	RBU, wide face, ≥ dia. 150 mm RBUP with composite body, ≥ dia. 150 mm	12, 13 21	1

Adapter pairs APM 50.8



With adapter pairs APM 50.8, wheel brushes, deburring brush type, and knotted stationary brushes can be used on all common tool drives. One set consists of 3 pairs of adapters.

Recommendations for use:

- Particularly suitable for applications which produce a lot of heat and involve high pressure

Ordering example:

EAN 4007220**900376**

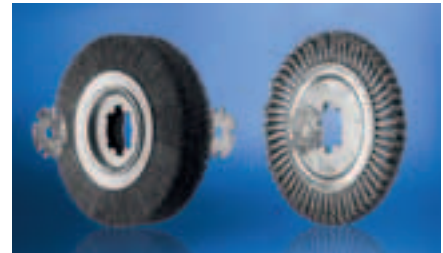

APM 50.8/16-20







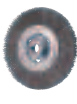













Description	EAN 4007220	Arbor hole dia. contained in the set [mm]	Suitable for	Page	
APM 50,8/16-20	900376	16.0 / 18.0 / 20.0	RGB, stationary brushes knotted RBU, deburring brush type	19 20	1
APM 50,8/22,2-30	900390	22.2 / 25.4 / 30.0	RGB, stationary brushes knotted RBU, deburring brush type	19 20	1
APM 50,8/32-40	900406	32.0 / 35.0 / 40.0	RGB, stationary brushes knotted RBU, deburring brush type	19 20	1



IP packaging
Robust industrial
packaging.

Description	EAN 4007220	Illustration
RBU = Wheel brushes, crimped		
POS RBU 10020/14,0 ST 0,30	956236	
POS RBU 10028/14,0 ST 0,30	956243	
POS RBU 12520/14,0 ST 0,30	956250	
POS RBU 12528/14,0 ST 0,30	956274	
POS RBU 15025/AK32-2 ST 0,20	956281	
POS RBU 15025/AK32-2 ST 0,30	956304	
POS RBU 15038/AK32-2 ST 0,20	956298	
POS RBU 15038/AK32-2 ST 0,30	956311	
POS RBU 18025/AK32-2 ST 0,20	956335	
POS RBU 18025/AK32-2 ST 0,30	956342	
POS RBU 18038/AK32-2 ST 0,30	956359	
POS RBU 20025/AK32-2 ST 0,20	956366	
POS RBU 20025/AK32-2 ST 0,30	956373	
POS RBU 20038/AK32-2 ST 0,30	956380	
POS RBU 10020/14,0 INOX 0,30	956397	
POS RBU 10028/14,0 INOX 0,30	956403	
POS RBU 12520/14,0 INOX 0,30	956410	
POS RBU 12528/14,0 INOX 0,30	956434	
POS RBU 15025/AK 32-2 INOX 0,20	956441	
POS RBU 15025/AK 32-2 INOX 0,30	956465	
POS RBU 15038/AK 32-2 INOX 0,20	956458	
POS RBU 15038/AK 32-2 INOX 0,30	956472	
POS RBU 18025/AK32-2 INOX 0,20	956489	
POS RBU 18025/AK 32-2 INOX 0,30	956496	
POS RBU 18038/AK 32-2 INOX 0,30	956502	
POS RBU 20025/AK32-2 INOX 0,20	956519	
POS RBU 20025/AK 32-2 INOX 0,30	956526	
POS RBU 20038/AK 32-2 INOX 0,30	956533	
RBU = Wheel brushes for angle grinders, crimped		
POS RBU 11512/M14 ST 0,30	806968	
POS RBU 12512/M14 ST 0,30	806975	
POS RBU 11512/M14 INOX 0,30	806982	
POS RBU 12512/M14 INOX 0,30	806999	
POLISCRATCH type		
POS RBU 10020/M14 SC ST 0,60	892459	
RBG = Wheel brushes, knotted		
POS RBG 10012/M14 ST 0,50	658970	
POS RBG 11512/22,2 ST 0,50	153512	
POS RBG 11512/M14 ST 0,50	658987	
POS RBG 12512/22,2 ST 0,50	530597	
POS RBG 12512/M14 ST 0,50	658994	
POS RBG 15013/22,2 ST 0,60	597996	
POS RBG 17813/22,2 ST 0,50	153413	
POS RBG 17813/M14 ST 0,50	659007	
POS RBG 17813/22,2 ST 0,80	578940	
POS RBG 11512/22,2 INOX 0,35	220795	
POS RBG 11512/M14 INOX 0,35	659014	
POS RBG 12512/22,2 INOX 0,35	530788	
POS RBG 12512/M14 INOX 0,35	659021	
POS RBG 17813/22,2 INOX 0,35	220733	
POS RBG 17813/M14 INOX 0,35	659038	

Description	EAN 4007220	Illustration
RBG CT = Wheel brushes, knotted, COMBITWIST® type		
POS RBG 11512/22,2 CT ST 0,50	593356	
POS RBG 11512/M14 CT ST 0,50	806814	
POS RBG 12512/22,2 CT ST 0,50	593363	
POS RBG 12512/M14 CT ST 0,50	806821	
POS RBG 17813/22,2 CT ST 0,50	593370	
POS RBG 17813/22,2 CT ST 0,80	593394	
POS RBG 11512/22,2 CT INOX 0,35	593400	
POS RBG 11512/M14 CT INOX 0,35	806838	
POS RBG 12512/22,2 CT INOX 0,35	593417	
POS RBG 12512/M14 CT INOX 0,35	806845	
POS RBG 17813/22,2 CT INOX 0,35	593424	
PBU = End brushes, crimped		
POS PBU 1516/6 ST 0,20	894491	
POS PBU 1516/6 ST 0,35	532256	
POS PBU 2020/6 ST 0,20	894514	
POS PBU 2020/6 ST 0,50	532263	
POS PBU 1516/6 INOX 0,20	894545	
POS PBU 1516/6 INOX 0,35	532287	
POS PBU 2020/6 INOX 0,20	894552	
POS PBU 2020/6 INOX 0,50	532294	
POS PBU 1516/6 SiC 180	532348	
POS PBU 2020/6 SiC 180	532355	
PBG = End brushes, knotted		
POS PBG 1919/6 ST 0,35	532416	
POS PBG 1919/6 ST 0,50	894361	
POS PBG 3030/6 ST 0,35	532423	
POS PBG 3030/6 ST 0,50	894422	
POS PBG 1919/6 INOX 0,35	532430	
POS PBG 1919/6 INOX 0,60	894460	
POS PBG 3030/6 INOX 0,35	532447	
POS PBG 3030/6 INOX 0,60	894484	
RBU = Shank mounted wheel brushes, crimped		
POS RBU 3006/6 ST 0,20	531808	
POS RBU 5015/6 ST 0,20	531822	
POS RBU 7015/6 ST 0,30	894606	
POS RBU 10010/6 ST 0,30	894613	
POS RBU 3006/6 INOX 0,20	531884	
POS RBU 5015/6 INOX 0,20	531891	
POS RBU 7015/6 INOX 0,30	894620	
POS RBU 10010/6 INOX 0,30	894637	
POS RBU 5015/6 SiC 180 0,90	531945	
POS RBU 7015/6 SiC 180 0,90	894644	
RBG = Shank mounted wheel brushes, knotted		
POS RBG 7006/6 ST 0,35	531969	
POS RBG 7006/6 ST 0,50	894569	
POS RBG 7006/6 INOX 0,35	531976	
POS RBG 7006/6 INOX 0,50	894576	
TBU = Shank mounted cup brushes, crimped		
POS TBU 5010/6 ST 0,30	532171	
POS TBU 5010/6 INOX 0,30	894651	
POS TBU 5010/6 SiC 180 0,90	894668	

Continued on next page

Brushes in POS packaging

Overview



Description	EAN 4007220	Illustration
TBU = Threaded cup brushes, crimped		
POS TBU 60/M14 ST 0,30	153543	32
POS TBU 75/M14 ST 0,30	220849	32
POS TBU 100/M14 ST 0,30 SG	153574	32
POS TBU 60/M14 INOX 0,30	721742	32
POS TBU 75/M14 INOX 0,30	220856	32
POS TBU 100/M14 INOX 0,30	220863	32
POS TBU 100/M14 SiC 120 1,00	530856	32
POS TBU 100/M14 SiC 180 0,90	530870	32
TBG = Threaded cup brushes, knotted		
POS TBG 65/M14 ST 0,35	153437	33
POS TBG 65/M14 ST 0,50	579121	33
POS TBG 65/M14 ST 0,80	579138	33
POS TBG 80/M14 ST 0,50	806654	33
POS TBG 100/M14 ST 0,50	806661	33
POS TBG 65/M14 INOX 0,35	220740	33
POS TBG 65/M14 INOX 0,50	598016	33
POS TBG 80/M14 INOX 0,35	806678	33
POS TBG 100/M14 INOX 0,35	806685	33
COMBITWIST® type		
POS TBG 65/M14 CT ST 0,35	806692	34
POS TBG 65/M14 CT ST 0,50	806708	34
POS TBG 80/M14 CT ST 0,50	806715	34
POS TBG 100/M14 CT ST 0,50	806722	34
POS TBG 65/M14 CT INOX 0,35	806739	34
POS TBG 65/M14 CT INOX 0,50	806746	34
POS TBG 80/M14 CT INOX 0,35	806753	34
POS TBG 100/M14 CT INOX 0,35	806760	34
KBU = Bevel brushes, crimped		
POS KBU 10010/M14 ST 0,35	220832	35
POS KBU 11510/M14 ST 0,35	806777	35
POS KBU 10010/M14 INOX 0,35	531129	35
POS KBU 11510/M14 INOX 0,35	806784	35
KBG = Bevel brushes, knotted		
POS KBG 10013/M14 ST 0,50	153529	35
POS KBG 11515/M14 ST 0,50	220818	35
POS KBG 12515/M14 ST 0,50	531167	35
POS KBG 10013/M14 INOX 0,35	220801	35
POS KBG 11515/M14 INOX 0,35	220825	35
POS KBG 12515/M14 INOX 0,35	531174	35
COMBITWIST® type		
POS KBG 10013/M14 CT ST 0,50	593431	36
POS KBG 11515/M14 CT ST 0,50	593448	36
POS KBG 12515/M14 CT ST 0,50	593455	36
POS KBG 10013/M14 CT INOX 0,35	593462	36
POS KBG 11515/M14 CT INOX 0,35	593479	36
POS KBG 12515/M14 CT INOX 0,35	593486	36
RBGIT CT = INOX-TOTAL wheel brushes, COMBITWIST® type		
POS RBGIT 11506/22,2 PIPE CT INOX 0,50	808511	39
POS RBGIT 11512/22,2 CT INOX 0,35	808528	39

Description	EAN 4007220	Illustration
HBU = Scratch brushes for universal application		
HBU 10 ST 0,35	659489	42
HBU 20 ST 0,35	572191	42
HBU 30 ST 0,35	572207	42
HBU 40 ST 0,35	572214	42
HBU 50 ST 0,35	153741	42
HBU 60 ST 0,35	713341	42
HBU 10 INOX 0,30	659496	42
HBU 20 INOX 0,30	572221	42
HBU 30 INOX 0,30	572238	42
HBU 40 INOX 0,30	572245	42
HBU 50 INOX 0,30	572252	42
HBU 60 INOX 0,30	713365	42
HBU 20 MES 0,30	572528	42
HBU 30 MES 0,30	572535	42
HBU 40 MES 0,30	572542	42
HBU 50 MES 0,30	572559	42
Bulk pack type		
HBU 30 GP ST 0,35	808320	42
HBU 40 GP ST 0,35	808337	42
HBU 50 GP ST 0,35	808344	42
HBU 40 GP INOX 0,35	808351	42
HBU LH = Scratch brushes Long Handle (LH)		
HBU LH 30 ST 0,35	616840	42
HBU LH 40 ST 0,35	616857	42
HBUP = Scratch brushes with plastic bodies		
HBUP 10 ST 0,40	906583	42
HBUP 20 ST 0,40	906590	42
HBUP 30 ST 0,40	906644	42
HBUP 40 ST 0,40	906651	42
HBUP 50 ST 0,40	906705	42
HBUP 10 INOX 0,40	906743	42
HBUP 20 INOX 0,40	906750	42
HBUP 30 INOX 0,40	906767	42
HBUP 40 INOX 0,40	906774	42
HBUP 50 INOX 0,40	906781	42
HBUP 20 MES 0,30	906712	42
HBUP 30 MES 0,30	906729	42
HBUP 40 MES 0,30	906736	42
HBK = Scratch brushes for fillet welds		
HBK 30 ST 0,35	572481	42
HBK 30 INOX 0,35	572498	42
HBG = Scratch brushes, curved type		
HBG 10 ST 0,30	153727	43
HBG 10 INOX 0,30	153734	43
HBG 10 MES 0,30	572672	43
HBZ = Scratch brushes for spark plugs		
HBZ 30 MES 0,15	572566	43
HBB = Scratch brushes/block brushes		
HBB 50 ST 0,35	572504	43
HBB 50 MES 0,30	573020	43
HBF = Scratch brushes for files		
HBF 10 ST 0,15	015315	43
HBFM = Scratch brushes for precision mechanics		
HBFM 40 ST 0,15	659502	43
HBFM 40 INOX 0,15	659519	43
HBFM 40 MES 0,15	659526	43

Note: All scratch brushes are supplied with a hanging hole and are therefore perfect for presentation on the PFERD TOOL-CENTER. For easy identification, all scratch brushes are marked with EAN, description and filament material.

Printed in Germany.

Subject to technical modifications.

02/2014

831 108

